

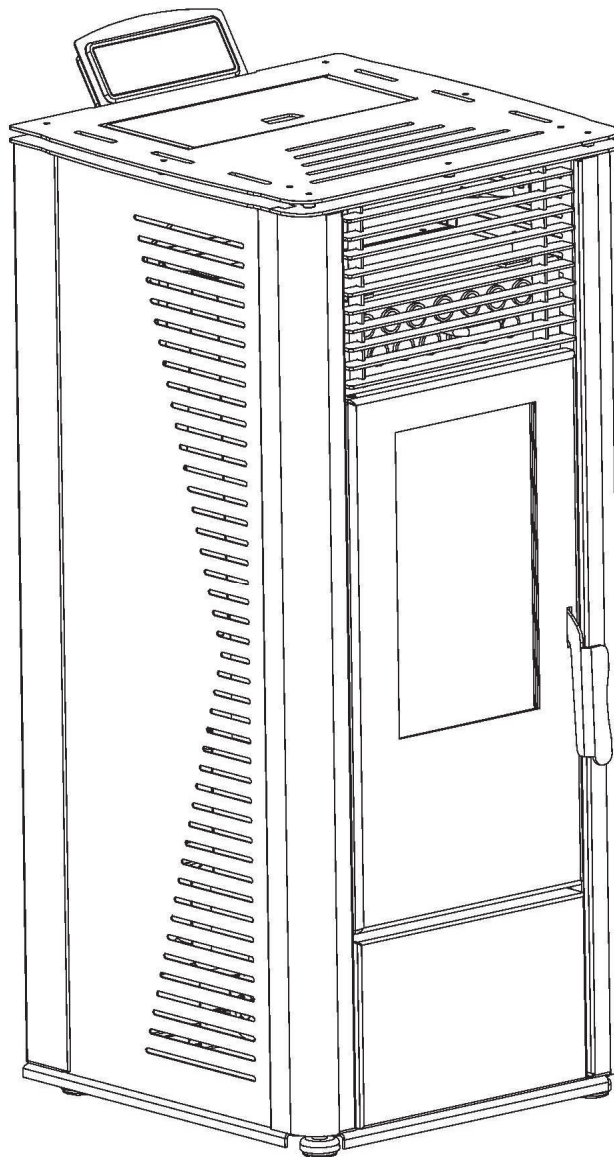

Maintenance and User Manual

Pellet Stoves



IMPORTANT!

This Appliance must be fitted by a HETAS / METAC Qualified Installer

Please keep these instructions for future reference.

Contents

1 Technical Parameter	2
1.1 Appearance and Three-dimensional View.....	
1.2 Technical Specification.....	4
2 Interface Introduction	5
3 Functions and Operation Procedures	6
3.1 Start.....	6
3.2 Turning off.....	6
3.3 Menu.....	6
3.4 Temperature set.....	10
3.5 Introduce of parameters for each power level.....	
3.6 Overload fuse.....	12
4 Operating instructions of remote controller	12
5 Installation of Stove	13
5.1 Assembly of Flue pipe.....	14
5.2 Floor Protection.....	14
5.3 Surrounding Safe Distance.....	15
5.4 Power Supply.....	15
5.5 Oxygen Supply for Combustor.....	16
6 General Steps and Instructions for operation	16
6.1 General Notes.....	16
6.2 Control Unit.....	17
6.3 Automatic Ignition.....	17
7 Cleaning and Maintenance	17
7.1 Ash clean up.....	19
7.2 Door glass cleaning.....	19
7.3 Hopper cleaning.....	19
7.4 Seal check.....	19
8 Faults - Causes – Solution	23
8.1 errors and solutions.....	23
8.2 Causes and solutions for faults.....	28
9 Wiring Diagram	30
10 Warranty and instructions.....	29

To apply for your warranty and see our list of Terms & Conditions please visit our website at :

<https://henleystoves.com/warranty/>

Dear Customer,

Thank you for choosing one of our products, the result of technological experience and continuous research to achieve superior quality in terms of safety, reliability, and service.

In this manual, you will find all the information and useful suggestions to use your product with the maximum safety and efficiency. Please read this manual carefully before you install and use our products.

Safety Precautions

Please comply with the following warnings:

- Read the manual carefully before first-time use.
- It is required to use handling tools to move the stove, thus preventing personal injury.
- The stove must be installed by local qualified professionals, in accordance with the requirements of the local laws and regulations.
- The socket shall be reliably grounded when the stove is being installed.
- Under normal combustion, it is prohibited to contact the stove surface, especially the door handles, glass and flue pipes and other high-temperature parts, without proper insulation protection measures.
- During using process, the elderly, children, and babies must stay away from the stove, until the stove temperature is cooled down to room temperature.
- Any heat-sensitive objects should be far away from the stove, clothes and other combustible materials are strictly prohibited to be placed on the stove.
- Do not directly dry the clothes on the stove! They might catch fire.
- The clothes racks should be far away from the stove ($\geq 1\text{m}$).
- Do not place flammable and explosive objects around the stove body while being in use.
- Pull the plug before cleaning and maintenance work.
- Use original parts only for replacement and maintenance.
- Please keep these instructions for future reference.



In order to maintain technological upgrading, the products are subject to technical upgrading or change without further notice!

Note: If there are any differences between the contents of the instruction and the product, please regard the actual product as the truth.

1 Technical Parameter

1.1 Internal Sectional Drawing

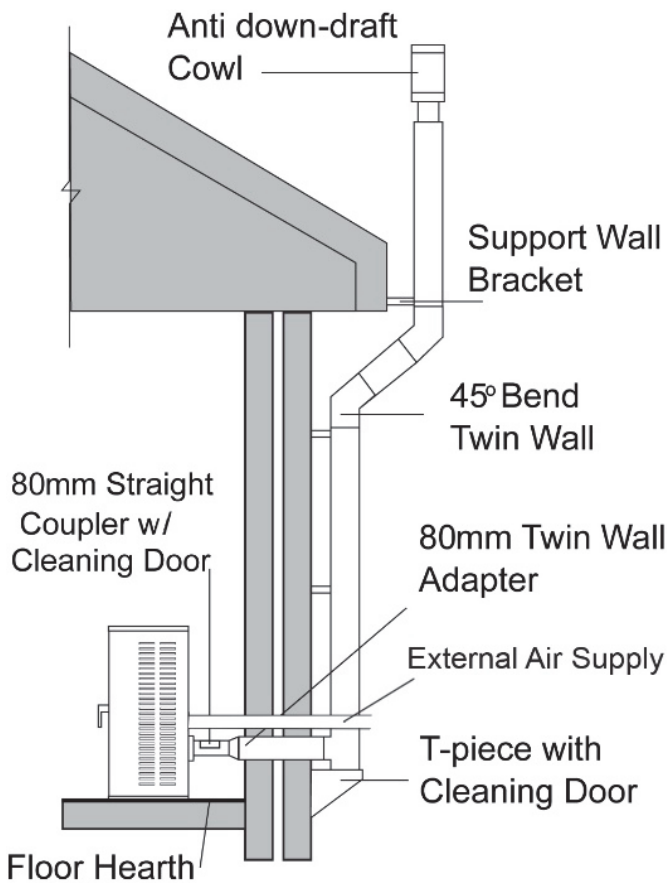
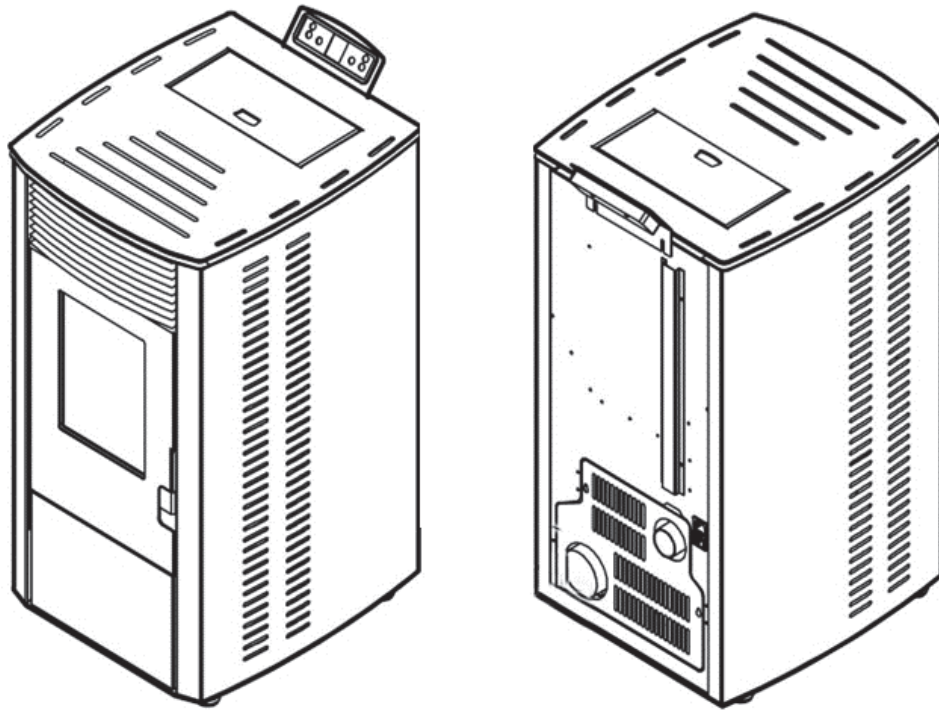

IMPORTANT
An anti-downdraft cowl and Cleaning door on pipework must be fitted with this appliance or your warranty will be null & void

1.2 Internal Sectional Drawings

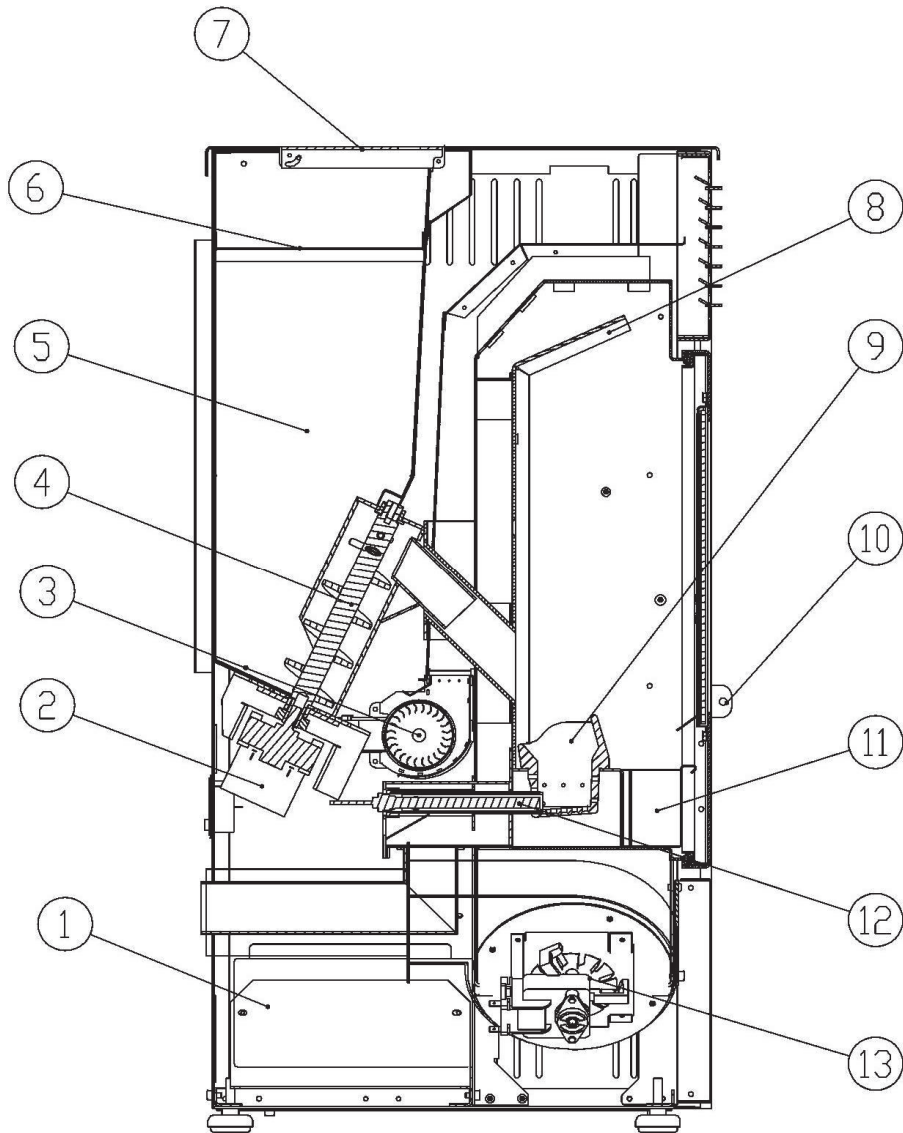

- ① Mother board
- ② Auger motor
- ③ Auger
- ④ Hopper
- ⑤ Grate in hopper
- ⑥ Ash-clean rod

- ⑦ Hot air output tube
- ⑧ Cover
- ⑨ Top thermal baffle in combustion chamber
- ⑩ Thermal baffle in combustion chamber
- ⑪ Door handle
- ⑫ burner

- ⑬ Convection blower
- ⑭ Ash box
- ⑮ Exhaust chamber
- ⑯ Exhaust motor



1.3 Technical Specification

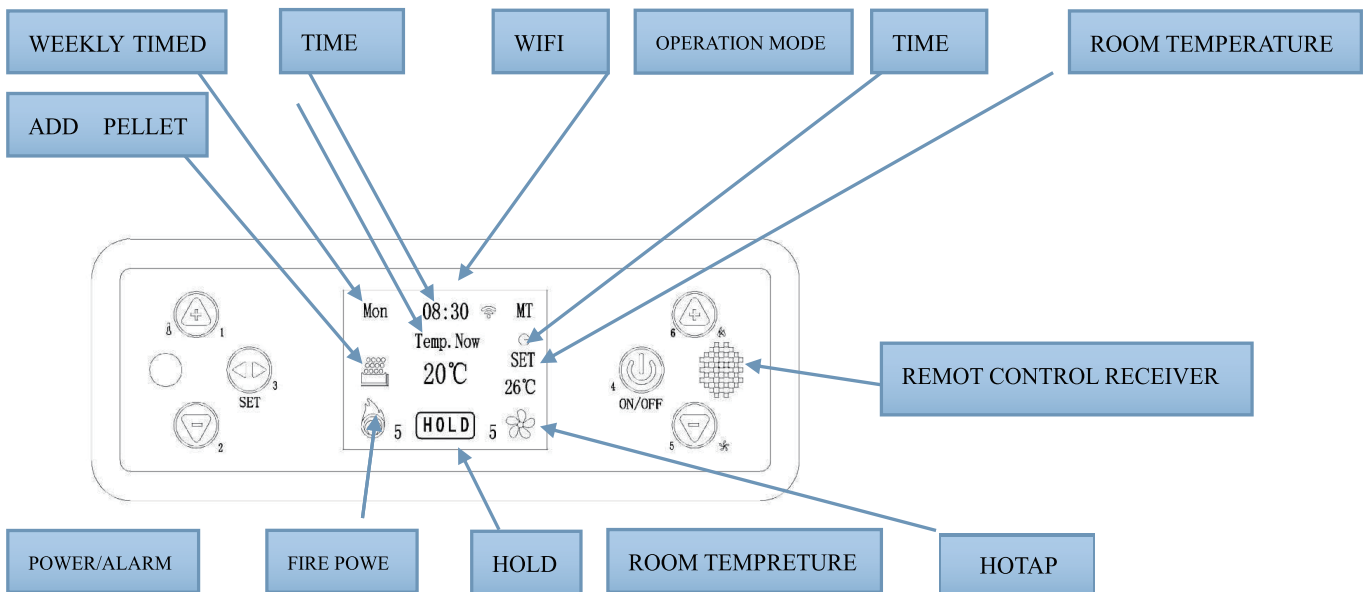

Z4	
Height	616mm
Width	385mm
Depth	426mm
Total Weight	51kg
Flue pipe diameter	80mm
Maximum power	4.2kw
Minimum power	3.2kw
Pellet Consumption	0.8-1.0kg/h
Hopper capacity	4.5kg
Power supply	220-240V/50Hz
Power consumption Max / Normal	350w / 80W
Electrical fuse	3.0 A
Flue gas mass flow	3.3-6.0g/s
Maximum flue gas temperature at output	ca.200°C
Minimum flue gas temperature at output	ca.105°C/
Minimum draft of chimney	Min.20Pa
Z8	
Height	909mm
Width	460mm
Depth	435mm
Total Weight	62kg
Flue pipe diameter	80mm
Maximum power	7.81kw
Minimum power	2.44kw
Pellet Consumption	0.5-1.6kg/h
Hopper capacity	426kg
Power supply	220-240V/50Hz
Power consumption Max / Normal	350w / 80W
Electrical fuse	3.0 A
Flue gas mass flow	3.3-6.0g/s
Maximum flue gas temperature at output	ca.200°C
Minimum flue gas temperature at output	ca.105°C/
Minimum draft of chimney	Min.20Pa

2 Interface Introduction





Description:

4  ON/OFF button; press  for 3 seconds to start or to stop the stove; short press to cancel or return.

3  Set key; press  to enter the setting menu, set the current time, combustion mode, timed ON/OFF.

1  Set room temperature key/Plus key .

2  Set room temperature key/Minus key .
While stove is in operation, press this key to check the smoke temperature.

6  Set fire power key, press this key to enter mode of setting fire power, weak to strong,F1 TO F5,press”+” or”-“ to adjust.

5  Set hot air speed key, press this key to enter mode of wind power set, weak to strong,S1-S3,press”+”or”-“ to adjust.

3 Functions and Operation Procedures

3.1 Start

Note: Burning pot must be checked and remove all the ash in it before starting.

Plug in power supply → power light lights up → long press  for 3 seconds → the screen lights and displays “ON” stove begins igniting.

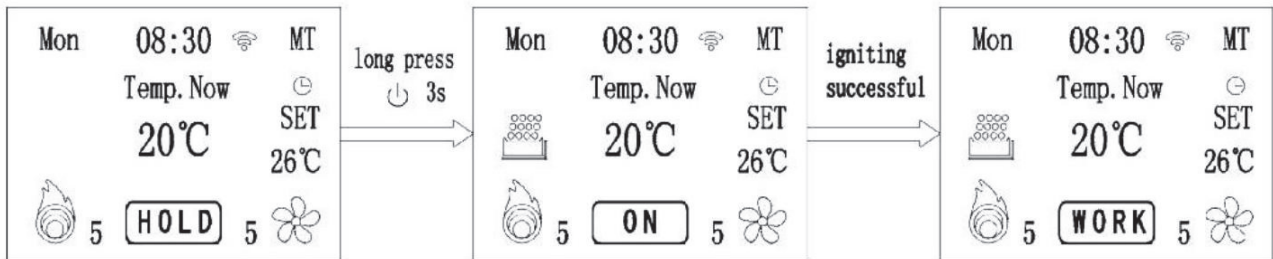

Note: First time use of new stove, there will be a little smoke and pungent smell, it is caused by heating the paint and slushing oil on plate, please open the window, after a short while of combustion it will disappear.

3.2 Turning off

Long press  for 3 seconds → the screen displays “TURNING OFF”, means that the stove enters into turning off phase, auger motor stops loading pellet, exhaust motor and convection motor continue working until the stove gets cool and smoke temperature gets lower than 50°C, then the stove enters into OFF mode.



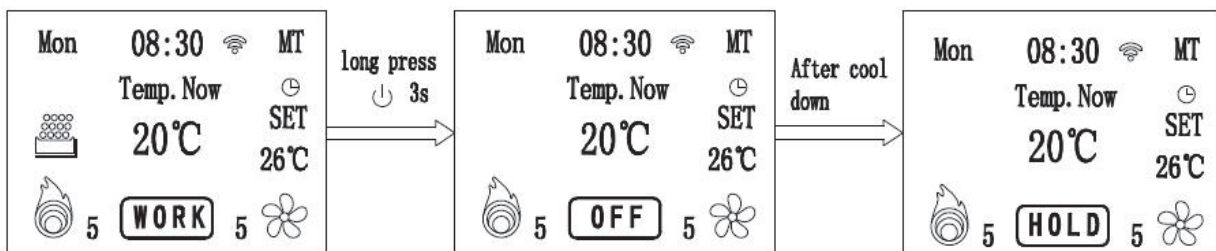

The screen appears as follows

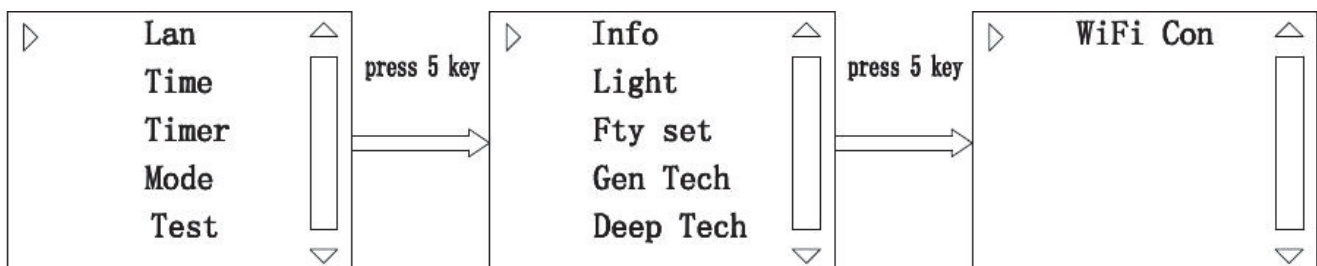

3.3 Menu

1. Press  , screen as blow:



2. When stove is working, press  key, appears successively the menu of LANGUAGE, TIME, MODE, WEEKLY, GEN TECHNICAL, DEEP TECHNICAL, LCD LIGHT, SELF CHECK, FACTORY SET, INFORMATION, WIFI. (As the above pic). Press   to scroll it, then press  it enters into the interface of the menu chosen.

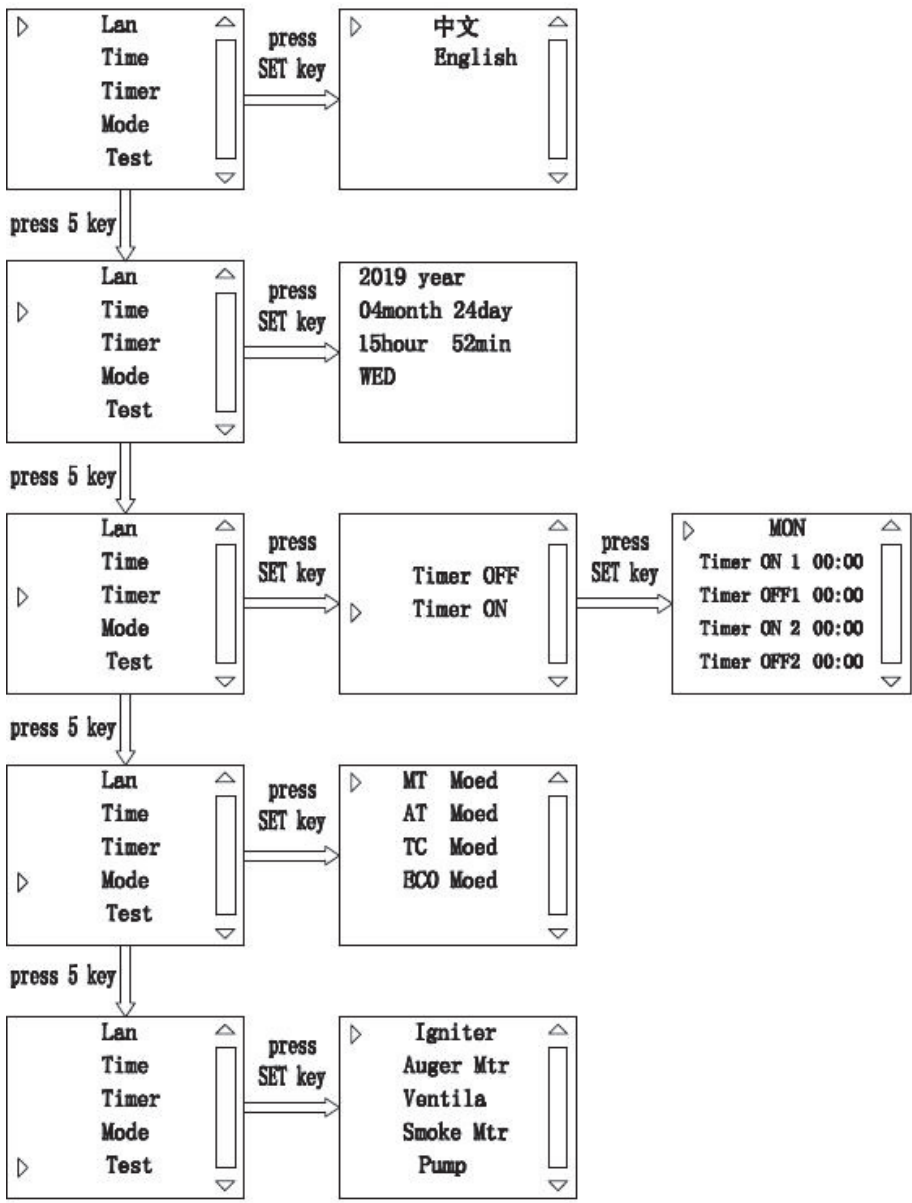

- MT** : operated by hand, fire power unadjustable automatically in this mode
- AT**: stove functions according to temperature sensor, once reached preset temperature stoves works at lowest fire power
- TC**: means stove functions according to indoor temperature control switch (indoor temperature control switch self-section), once reached preset temperature stoves works at lowest fire power for 15 mintues, if the room temperature keeping on increasing the stove stops working. When temperature is 2°C lower than preset temperature, stove reignites.
- ECO**: means stove once not reached preset temperature stoves works at highest fire power, once reached preset temperature stoves works at lowest fire power for 15 minutes if the room temperature keeping on increasing the stove stops working. When temperature

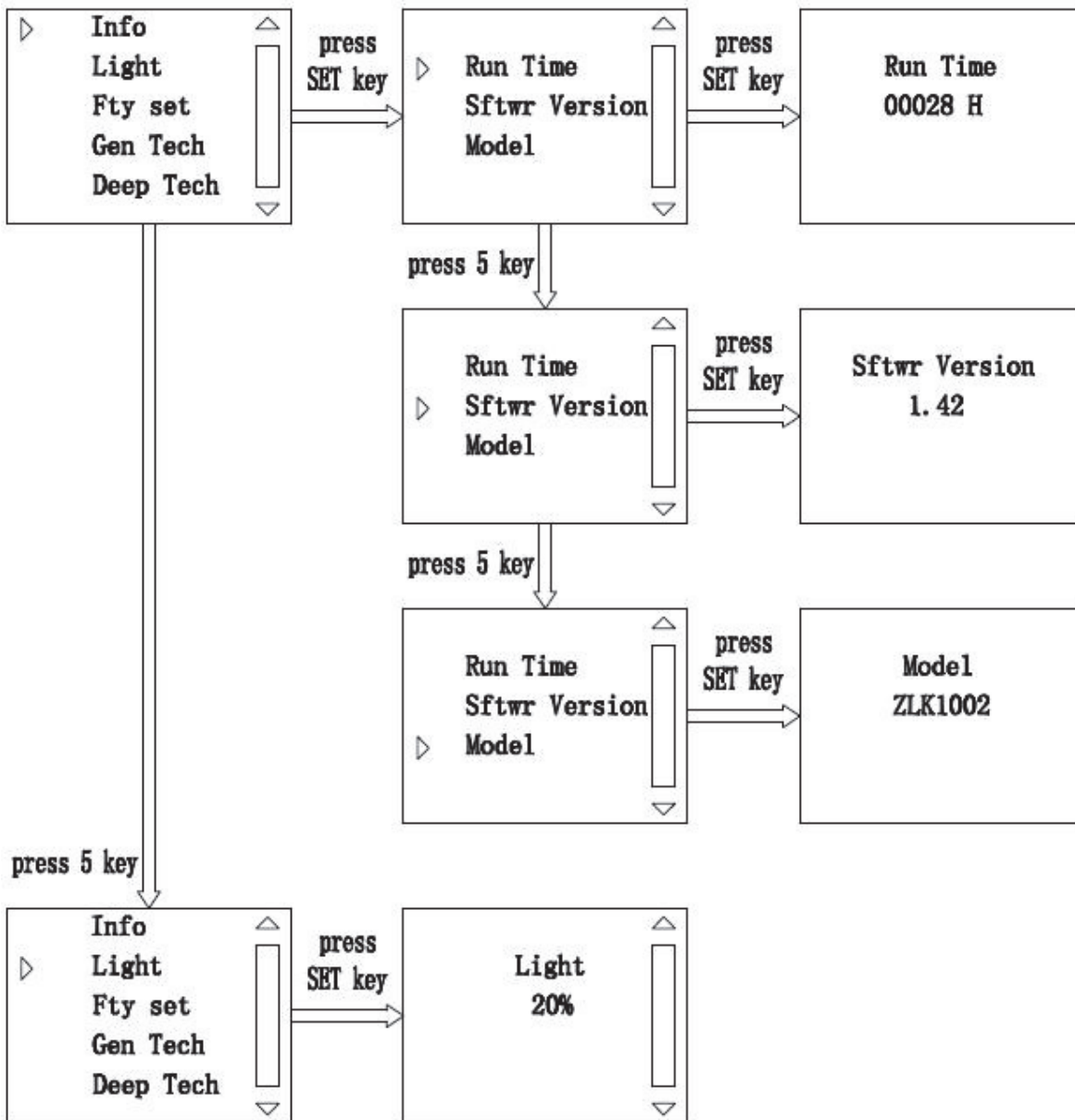

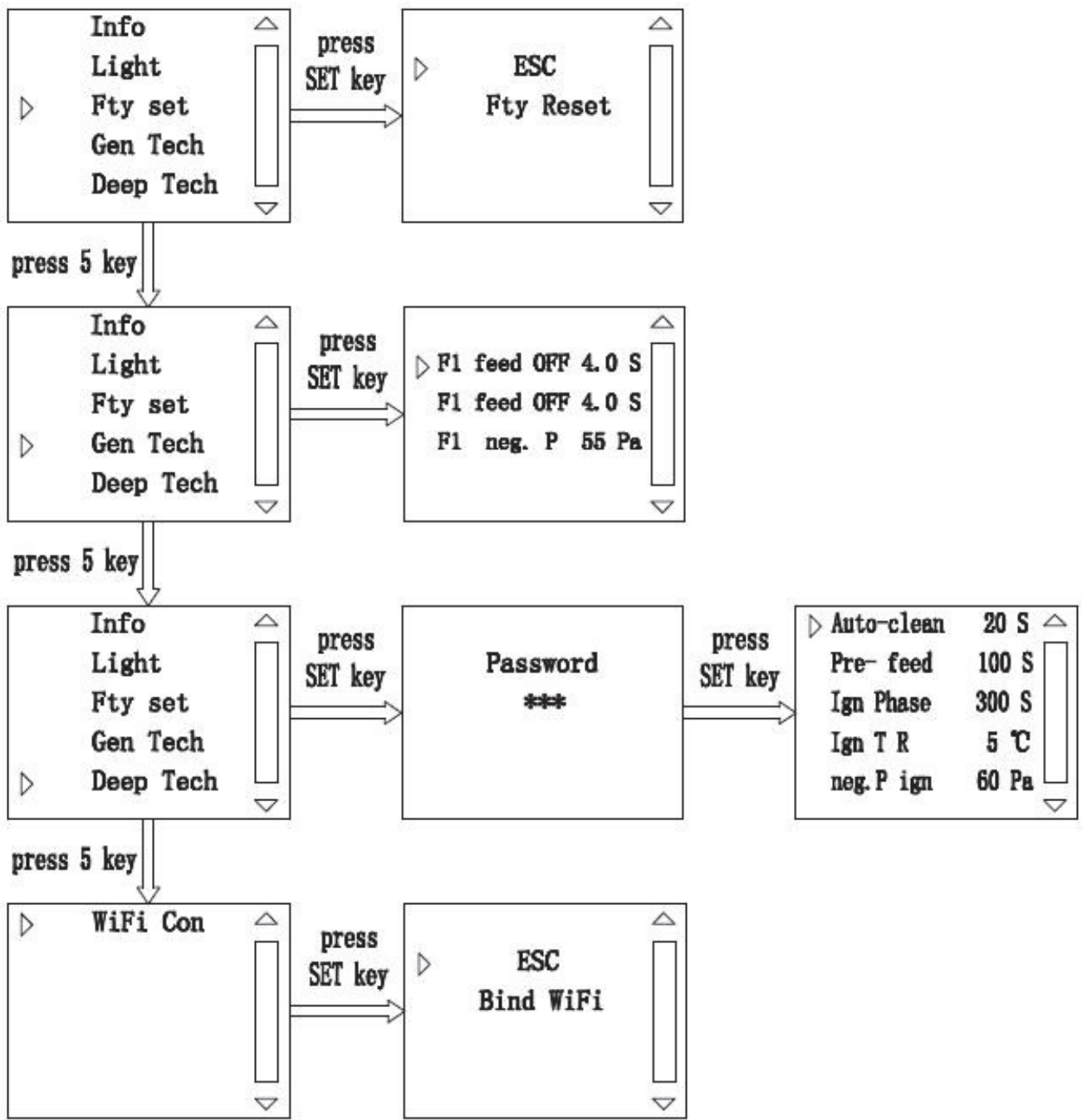

LANGUAGE: two options including Chinese and English

TIME: appears in sequence as year, month, date, hour, minute, weekday

WEEK TIMER: it means stove automatically turns on TIME ON1 at 0:00 , turns off TIME OFF1 at 00:00, then turns on TIME ON2 at 0:00TIME OFF2 at 00:00.

SELF-CHECK: In standby state, you can check whether the ignite, auger motor, convection blower, Exhaust motor is electrified properly.

INFORMATION: Check the total running time, program version, and fireplace model.

LIGHT: Display Backlight Brightness

FACTORY SET: restore factory defaults. (if you need modifying please contact with professional staff before modifying)





GEN TECHNICAL: this allows to set work period and stop period of auger motor and speed of exhaust motor at every fire power level while stove working. (if you need modifying please contact with professional staff before modifying)

DEEP TECHNICAL: this allows to set work period and stop period of auger motor and speed of exhaust motor at each igniting phase, set the temperature for defining igniting success.(if you need modifying please contact with professional staff before modifying)

WIFI CONNECTION: WIFI wireless module selection, specific operation instructions see the APP operation instructions.



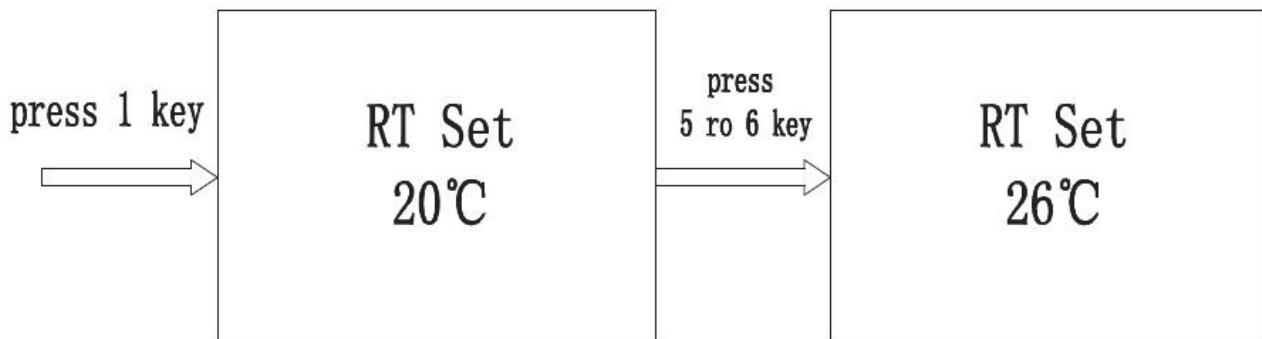

3.4 Temperature set

Set room temperature

Power on, press ₁ key, set the temperature as you want, press ₁ or ₂ can increase or decrease, press ₄ key to exit.



Set fire power level



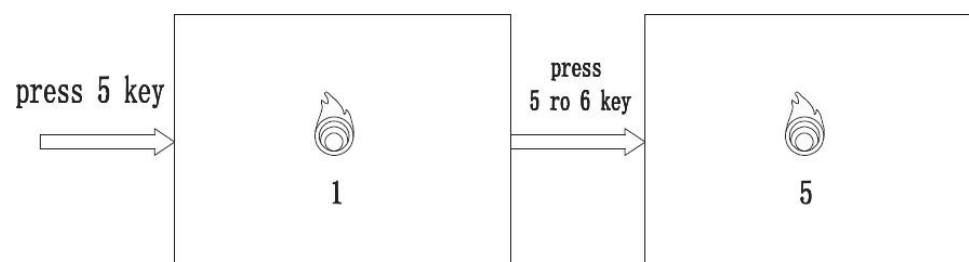

Press ₆ to enter into mode of fire power set, 5 fire power levels, ranging from 1st level to 5th level, 1st level is the weakest level while 5th level is the strongest level. 1 frame on display is 1st level, 2 frame on display is the 2nd level, etc. Press ₆ or ₆ to adjust, then press ₆ to confirm and exit.



Parameters have been configured in factory, normally it doesn't need any adjustment. In adjustment because of pellet calorific value difference, please avoid too much pellet load, it will cause too strong fire, thus wasting the pellet and shortening the service life of stoves. This is the way to check whether the fire is too strong: during normal operation, press  to check temperature of exhaust, it should be less than value rated by factory, $\cong 200\text{ }^{\circ}\text{C}$. If exhaust temperature is too high, it means the fire is too strong, please reduce pellet load quantity properly in the present fire power level.

Flue T	166.5°C
Chamber P	83 Pa
Flue N P	65 %

Set convection motor speed

Press  to enter into mode of convection motor(ventilator) speed set, 5 speed levels, ranging from 1st level to 5th level, 1st level is the weakest level while 5th level is the strongest level. 1 frame on display is 1st level, 2 frame on display is the 2nd level, etc. Press  or  to adjust, then press  to confirm and exit.

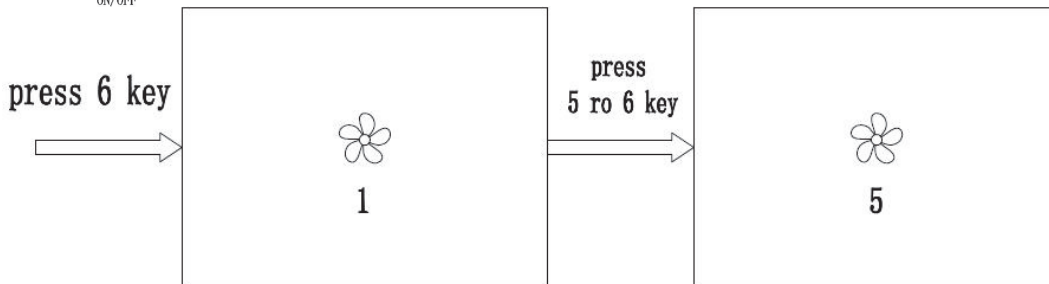

3.5 PARAMETERS SET

(ZLK1002 Example) GEN PARAMETERS

PARTS	power level1	power level 2	power level 3	power level 4	power level 5
Auger Motor	OFF: 4.5 S ON: 1.5 S	OFF: 5.0 S ON: 2.0 S	OFF: 4.5 S ON: 2.5 S	OFF: 4.0 S ON: 2.5 S	OFF: 3.5 S ON: 2.5 S
Exhaust Motor	43	44	45	46	48

Auger Motor: Min. Adjustable scale is 0.1 S, ON/OFF adjustment scales is 0-9.9S, such as power level 1 off of 4.5 S and on of 1.5 S, mean a period the auger motor stop for 4.5 S and works for 1.5 S then loop.

Exhaust Motor: adjustment range 0%-100% (0V-230V), the bigger of the value, the working of the fastest speed ,(E.g.):100, of the max. speed ,1, the min. of lowest speed.

Note.: This parameter is only for reference, because the different calorific value of pellet also need to change its parameters!

3.6 Over load fuse

There is a tube fuse in the power plug at the back of stove to avoid overvoltage and overcurrent. When the fuse burns out, please replace it with the same standard fuse.

Note: one spare fuse exists in the three-in-one switch.

4 Operating instruction of remote controller

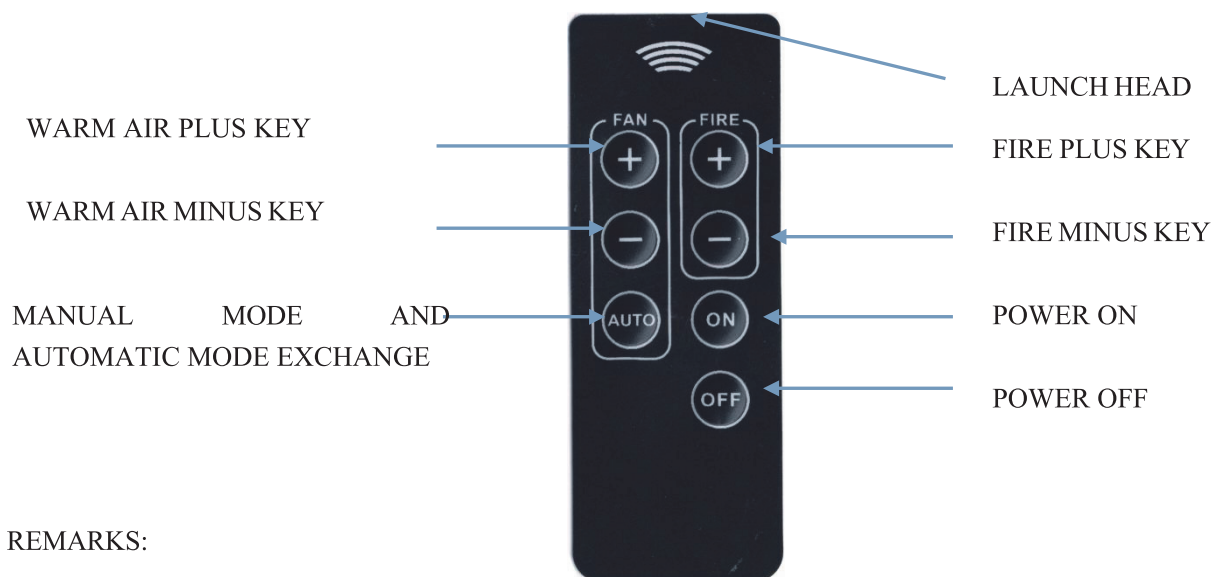

REMARKS:

- 1) In operation, remote control launch head must heat to the operation panel remote control receiving head, when push to the next step, confirm whether there is a reaction, such as buzzer voice.
- 2) Remote control battery loops for lithium-ion batteries, when not in use for a long time, please remove the battery, battery specifications: CR2025.

5 Installation of Stove

- The stove must be installed on a suitable, solid, and horizontal floor.
- The minimum diameter of flue pipe is 80mm, and such a tube should be made of metal or other heat-resistant materials which can resist more than 220°C
- An anti-down draft cowl must be fitted when installing the stove.
- The joint of the flue pipe must be sealed because the stove can only work on basis of the differential pressure in stove and draft in the chimney to protect the system.
- Try to avoid bend connection from up direction to down direction. Horizontal pipes had better to upsweep about 3—5° , vertical pipes height $\geq 3M$, to create proper differential pressure, but the whole length of pipes shall be less than 8M.
- Exhaust pipes must be only used for this stove, no shared use with other items.
- Flue pipes may be only made of heat-resistant and flame-retardant materials
- Don't locate the pipe outlet at closed or semi-closed regions, such as a carport, garage, attic, low area narrow corridor etc. these regions might gather exhaust. The pipe outlet must be at least 10M away from the flammable items.

- Decrease-diameter-installation is forbidden, there should be device that prevents smoke back and rain.
- The stove must be properly connected with flue pipe by your installer
- The stove must be properly connected with flue pipe by your qualified installer in accordance with the requirements of the local and EU laws and regulations.
- Note: The installation of the stove must be in compliance with the local regulations and rules.

5.1 Assembly of Flue pipe

Please refer to the current issues of [British Standards BS EN 15287-1:2007](#) - design, installation and commissioning of chimneys before commencing installation. The chimney draw is critical on any installation and should be checked to ensure that it matches what is specified. If the draw is higher than recommended, we advise that provision must be made to correct the overdraw. The draw can vary in different weather conditions and the customer should be made aware of this. **An anti-downdraft cowl and Cleaning door on pipework must be fitted with this appliance or your warranty will be null & void.**

Failure to correct an over-drawing flue will invalidate the warranty and may damage the appliance. Please remember that chimney draught is dependent on four main factors.

- Flue gas temperature
- Flue height
- Flue size
- Flue terminal

The flue or chimney system must be in good condition. It must be inspected by a **HETAS /MECTAC Qualified Installer** and passed for use with the appliance before installation. Products of combustion entering the room can cause serious health risks.

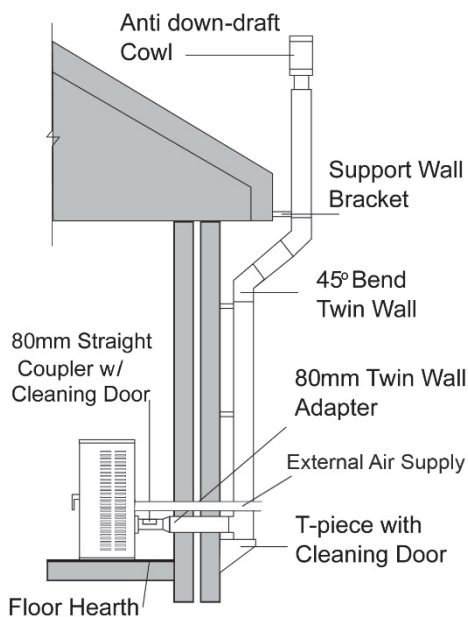

- The construction of the masonry chimneys, flue block chimneys & connecting flue pipe system must meet requirements of the Building Regulations. We recommend a flexible flue liner system certified for use with solid fuel systems be used to improve stove performance. The flue liner must be removed when an appliance is replaced, unless proven to be recently installed and in good condition.

The installation of manual draft adjustment devices on forced draft appliances is not permitted.

- The minimum height of the flue or chimney must be 4.5m from the hearth to the top of the flue, with no horizontal sections & a maximum of 4 bends. Bends must have angles of less than 45 degrees from the vertical. Ensure the connecting flue pipe is kept a suitable distance from any combustible material and does not form part of the supporting structure of the building.

Make provision to remove the appliance without the need to dismantle the chimney. Any existing flue must be confirmed as suitable For the new intended use as defined in the Building Regulations. The flue or chimney systems must be inspected and swept to confirm the system is structurally sound and free from obstructions.

- It is not possible to connect the appliance to a flue shared with other combustion appliances or in the presence of hood exhausts. It is forbidden to use the direct drain on the wall or towards closed spaces and any other form of drainage not provided for by the legislation in force in the country of installation. It is recommended to check the safety distances that must be respected in the presence of combustible materials and the type of insulating material to be used (data that can be found directly from the flue plate).

If the chimney is believed to have previously served an open fire it must be swept a second time within a month of regular use after installation to clear any soot falls that may have occurred due to difference in combustion levels. The flue exit from the building must comply with local building control rules. Do not connect or share the flue or chimney system with another heating appliance. Do not connect to systems containing large voids or spaces over 230mm square.

5.2 Floor Protection

In case of a flammable flooring (such as wood or carpet floors), a fire-resistant protection hearth is required, such as glass, steel, ceramic and so on.

Fire-resistant protection mat must be larger than the contacting area between the stove and floor.

Front wall: min. 500mm

Each side wall: min. 300mm

As shown below:

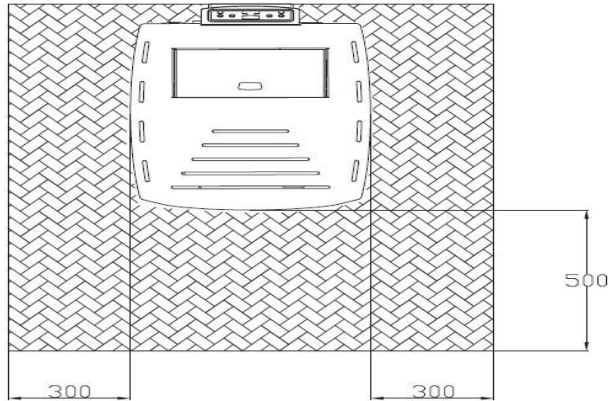

5.3 Surrounding Safe Distance

Corner : min. 250mm

Back: min. 250mm

Side: min. 350mm

Front: min. 1000mm

As shown below:

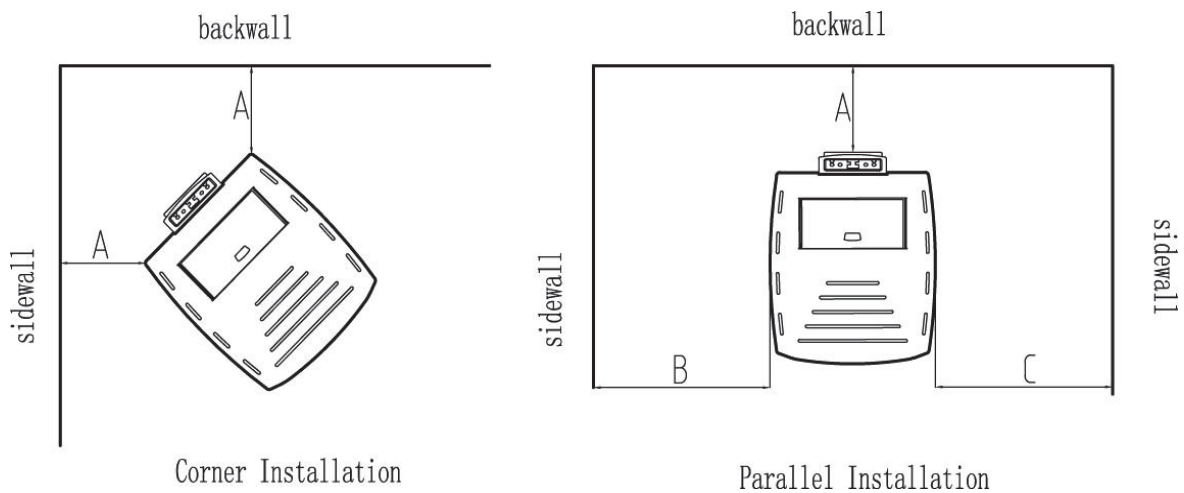

5.4 Power Supply

European-style / three-hole socket/plug; 230V/50Hz

American-style / three-hole socket/plug; 110V / 60Hz

Normal power consumption: 80w

Ignition stage: 340W (about 5 minutes);

In order to avoid safety threats, the connecting cable must be kept away from heat or sharp parts;

The socket must be reliably grounded.

5.5 Oxygen Supply for Combustor

During the burning process, the stove must draw air from the outside room. We recommend using the external air supply. If not, you must ensure the room has good ventilation, open windows or doors, or install a proper air supply system.

6 General Steps and Instructions for operation

6.1 General Notes

The stove must be installed correctly

It is required to use high-quality pellets (pellet standard is DIN 51731, and OENORM M 7135, or similar). Pellet diameter: 6mm, length \cong 25mm.

Initial use phase, please try different brands pellets, choose a brand that owns high calorific value but low ash content and low coking possibility. High-ash-content pellet will increase frequency of cleaning, and too-much-water pellet will block the auger thus causes inoperation of stoves.

The product is neither suitable for burning wood, nor functions as an incinerator.

It is strictly prohibited to put any waste, garbage, and a variety of plastics in the stove for burning. This is illegal, and the warranty terms and articles herein will be invalid if any above situation exists.

If used the stove in accordance with the manual, overheating is not possible.

Improper operation against instructions may damage the electrical components (such as fans, auger motor, control unit, etc.) and reduce their working life.

6.2 Control Unit

The stove is equipped with micro-processor and control components

All functions and setting can be realized through the operation panel mounted on top of the stove.

Modifications to defaults should be approved by a professional.

Incorrect use or settings may cause damage to the stove, and make the warranty terms and articles herein invalid.

6.3 Automatic Ignition

Long press the  key, and the stove will automatically ignite; about 7 minutes later, the pellets begin to burn.

Ignition Solution in case of an auto-ignition failure

In case of an auto-ignition failure, please remove all the pellets in the burner pot, and place the burner properly and restart the stove. Otherwise too much pellet in burner in igniting phase will cause detonation.



Re-filling of wood pellets

Attention! Fire hazard!

Please keep pellets plastic bags far away from the stove while feeding pellets.

Pellets should not be overflowed from the hopper cover; the overflowed pellets must be cleaned to avoid accidents.

In order to prevent fire from extinguishing, make sure to keep the pellets in a proper filling level in the hopper. You can refill pellets if you can see the auger at the bottom of the hopper.

The storage height of pellets should be checked regularly.

Except for the feeding process, the hopper cover should be closed in any cases.

Attention! To prevent high-temperature burns, please always wear protective gloves to open the hopper cover.

7 Cleaning and Maintenance

General

Attention! Before doing any maintenance work, it is necessary to turn off the stove and wait till it's cooled down to room temperature, then pull the plug

The cleaning interval depends on pellet quality and average heating power.

Moist or high-ash & sawdust pellets may disrupt normal cleaning interval. Therefore, please always use high-quality pellets.

Maintenance schedule (Refer)

	1	2-3	15	30	1
	●				
		●			
		●			
		●			
				●	
					●
Door Frame Sealing Strip					●
					●

7.1 Ash cleanup

Wood does not only contain carbon and hydrogen, but also the mineral components.

This incombustible material remains in the stove is ashes. This is natural residue and can be disposed as garbage or used for fertilizer.

Do not put hot ashes in the trash as the remaining fire may ignite the garbage.

Take ashes from the stove, put out with water, and wait a moment before disposal.

Please place ashes in the metal ash pans or small boxes.

Every 2—3days please check the ash box and remove the residue in it while it is cold.

Metal bucket vacuum is suggested to use while the ash is completely cold.

Cleaning of burner pot

Check the burner pot regularly before use. Make sure the air duct is free from ash, soot or slag. The burner pot should be correctly placed in the chamber.

When the burner pot is cooled down to room temperature and has no flame in it, then the vacuum cleaner can be used for cleaning ashes.

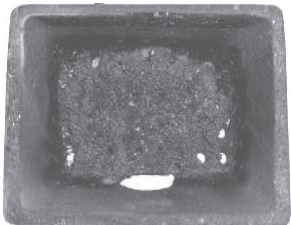

Example of dirty grate



Example of clean grate

Cleaning of burner pot base

Every time when cleaning the burner pot, please check the base under it for ash, if too much ash exist it will decrease oxygen quantity in chamber thus cause bad combustion. Please clean the base with metal vacuum cleaner.



Example of dirty base



Example of clean base

Attention! Only when it is cooled to room temperature, and there is no flying ember, the vacuum cleaner can be used for cleaning ashes.

Cleaning of ash box

Every 2 or 3 days please check ash in ash box and remove it.

Only when ash is cooled to room temperature, and there is no flying ember, the vacuum cleaner can be used for cleaning ashes.



Example of dirty ash box



Example of clean ash box

Cleaning of flue tubes inside the stove

Door Glass Cleaning

The grime on the glass will change from black to brown, yellow and stone-gray because of the pellet quality and wood species. Wipe the grime with a damp cloth or windows eraser. Do not use caustic cleaning agents or hard metal brush to clean fouling, otherwise, the high-temperature resistant glass may be scratched or corroded.



Example of dirty glass



Cleaning the glass



Example of clean glass

Cleaning of heat-exchange pipes

(the vacuum cleaner available)

Every time before starting the stove, please push-and-pull ash cleaning rod for several times, it will help to enhance heat exchange efficiency.

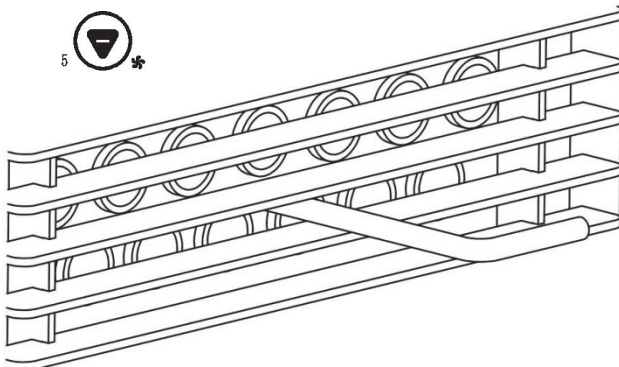

push-and-pull for several times

Cleaning of anti-fire-plate in top chamber

Every 2 weeks, before start the stove, manually move this plate slightly upward and forward, then you can get it out, remove the ash on it and relocate it correctly after cleaning, please pay attention to the three snap joint when relocate it.



7.1 Cleaning of flue tubes inside the stove

The flue tubes inside the stove are required to clean at least twice a year, or when about 500 kilograms of pellets have been burned out, or the stove has worked for more than 300 hours. Both ends of pipes should be cleaned.

- Manually take the top cover upward to remove it.
- Disassemble the side panel.
- Take off 6 screws on plate cover of ash-clean open with hexagon socket key(4mm).
- Remove 3 plate cover and 3 gasket seal.
- Clean ashes from the flue tubes with a metal vacuum cleaner.
- After cleaning assemble in inverted order, pay attention to relocate the cover plates correctly and firmly sealed.

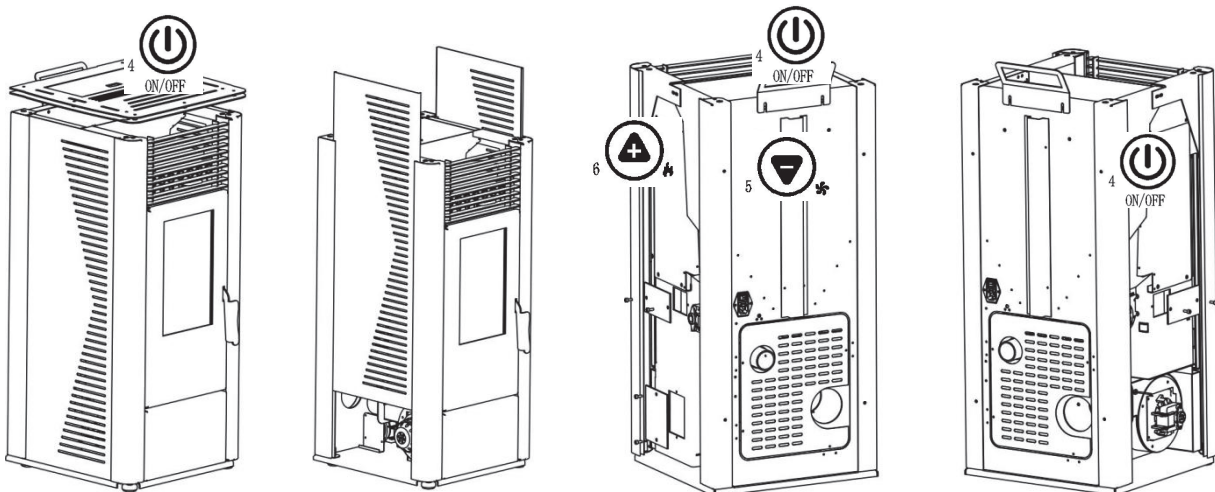

Clean the ash collector of exhaust chamber

Ash collector of exhaust chamber is fixed on the rear bottom of the combustor

- Remove the back cover of stove;
- Remove the screws of two covers on exhaust device.
- Remove two covers.
- Sweep ashes inside with a vacuum cleaner.
- Please ensure the seal is firmed without leakage before reinstalling the cover.

7.8 Cleaning of smoke blower

In order to check and clean smoke blower, please unscrew the four hex head bolts of smoke blower, slowly remove the blower, use a vacuum cleaner to remove ashes in tubes or blower. Please ensure the seal is firmed without leakage before reinstalling.

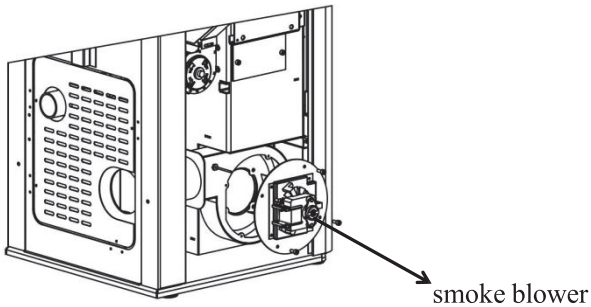

7.2 • Cleaning of smoke pipes

After the heating season, manually remove the T cover downward, make it clean and then relocate it, please be sure that it is relocated correctly and firmly sealed.



T cover



Example of dirty cover



Example of clean cover

7.3 Hopper Cleaning

In the period when the stove is out of use, you should remove all pellets from the hopper with a vacuum cleaner with a long extension. If the fuel is left in the hopper, it may get damp, stick together, and be difficult to light at the beginning of the next season

If the nozzle of the vacuum cleaner can not match with the grid on the hopper cover, please remove the grid to facilitate cleaning.

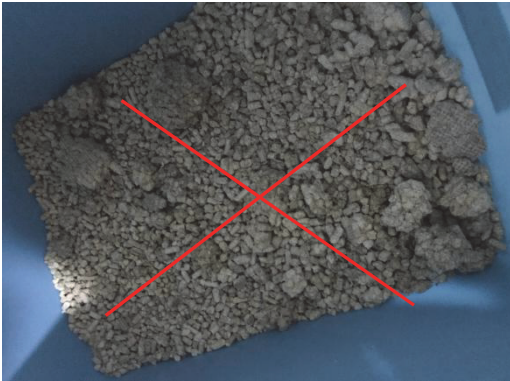

Caking poor quality pellet



Recommended good wood pellet

Attention: pull out the plug before cleaning.

7.4 Seal check

The seal ropes of door and glass should be checked at least once a year. Put a piece of paper between seal cord and surface of chamber, close the door, pull out the paper, if failed to pull it out it means sealed firmly. If the paper can be pull out it means the seal cord is damaged, please have them repaired or replaced.

8 Faults - Causes – Solution

8.1 errors and solutions

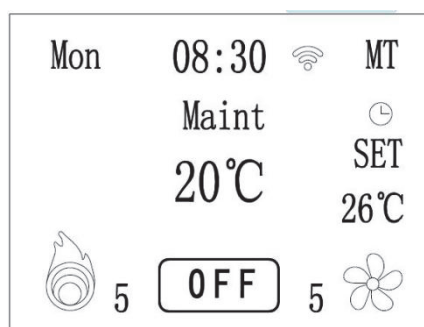

ALARM 1:

Cause: Maintenance time now, need to check the whole stove, to do some clean up, program checking and so on.

Solution: Enter the interface of DEEP TECHNICAL, find maintenance time and make it twice of its original number. For example, if the original number is 30, after seeing ALARM MAINTENANCE please make it 60, in the future when you see this alarm again then make it 90, the rest can be done in the same way.



ALARM 2:

Cause: Ignition failure

Solution: 1. Check pellet exists or not in hopper, refill if not.

2. Check slag-bonding exists or not in combustion bowl, please remove slag-bonding if it exists, and then relocate the bowl at right position.
3. Ignition succeeding but alarms also, maybe pellet feeds too little, please adjust 4PB, 5PB to enlarge pellet feeding.

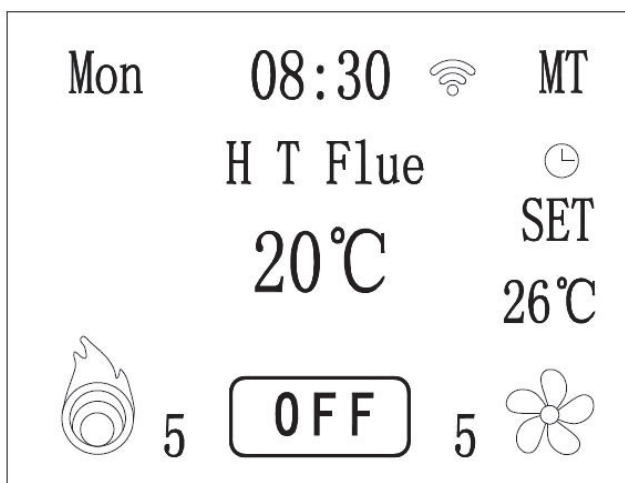

ALARM 3:

Cause: Over temperature of flue gas

Solution: Decrease pellet feeding of auger motor in Chart 2.

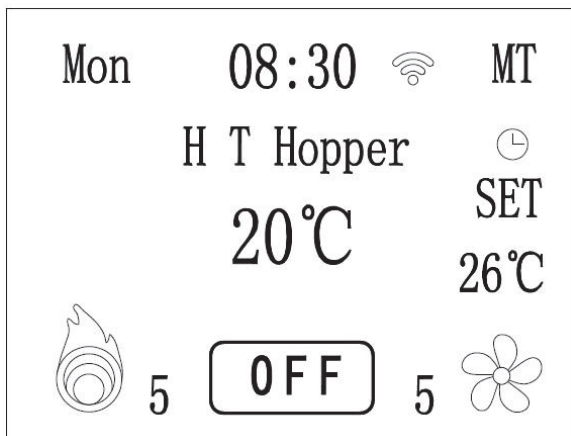

ALARM 4:

Cause: Over temperature in hopper.

Solution: 1. Decrease pellet feeding of auger motor in Chart 2.

2. Fault of switch of temperature control in hopper, replace with a new switch.

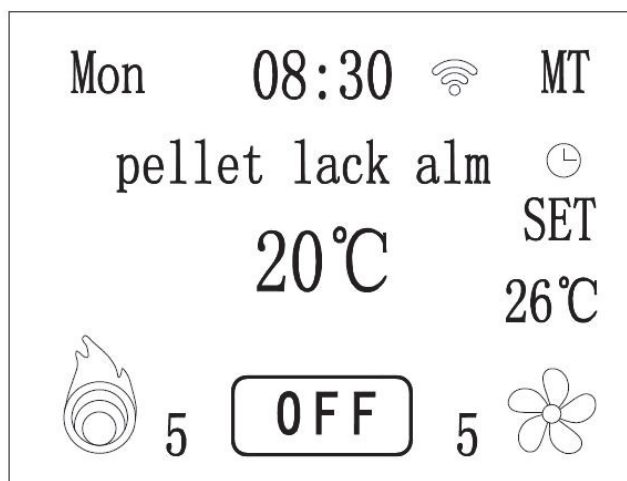

ALARM 5:

Cause: Hopper is empty.

Solution: Fill the hopper and re-start the stove.

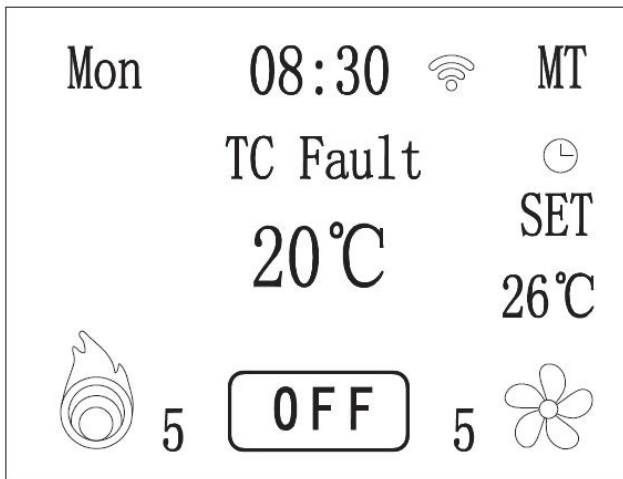

ALARM 6:

Cause: Thermocouple problem, wrong match with or poor contacting with anode and cathode.

Solution: 1. Check the contacting of the thermocouple.

2. Change the thermocouple.

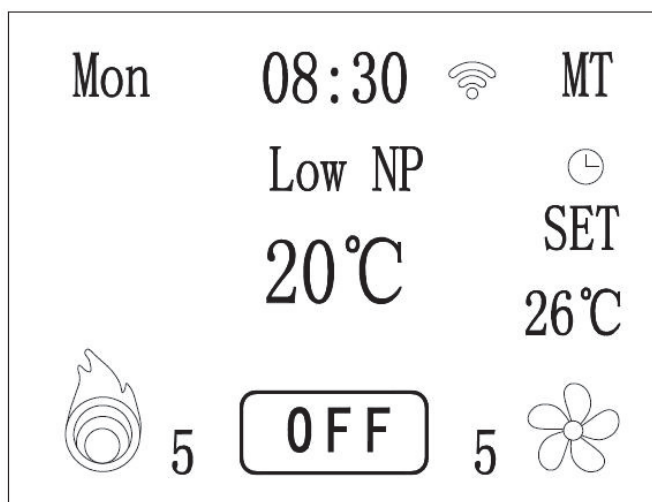

ALARM 7:

Cause: Pressure switch problem, or flue pipe with too low negative pressure.

Solution: 1. Re-check or change the pressure switch.

2. Re-check or change the exhaust motor.

3. Re-check and close the door.

4. Check and clean the flue pipes.

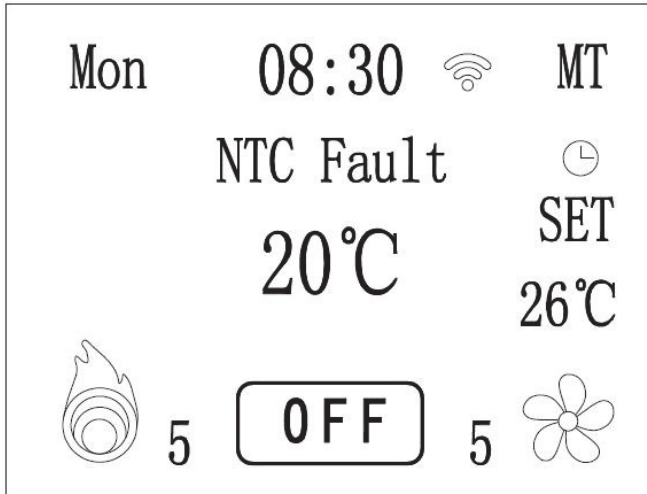

ALARM 8:

Cause: Temperature sensor problem or poor contacting.

Solution: 1. Check the contacting.

2. Change the temperature sensor.

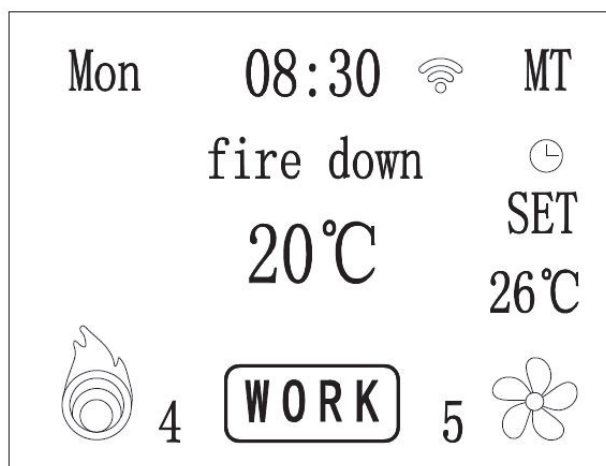

ALARM 9:

Cause: Over temperature of flue gas.

Solution: 1. Decrease pellet feeding.

2. Change the mandatory downgrade temperature (after contacting the distributor).

8.2 Causes and solutions for faults

Item	Faults	Causes	Solutions	Remarks
1	Fire is burning weakly with orange flame; front glass gradually turns black and burner pot is filling up with pellets	No enough air for combustion	<ol style="list-style-type: none"> 1. Burner pot must fit tightly in its holder. Check its fit.. 2. Clear ashes and slag to ensure smooth ventilation. If necessary, please replace with higher-quality pellets. 3. Check the air inlet duct and flue. And ensure they are empty and clean. 4. Check the chimney without too much soot. 5. Check the tightness of the stove door. 6. Check if Smoke blower is properly working 7. Have the stove checked and cleaned by your dealer or a certified technician. 	
2	The fire is extinguished, and the stove stops running.	<ol style="list-style-type: none"> 1. The hopper is empty; 2. Pellets can't be conveyed 3. The chamber temperature is too low; 4. The front door is not sealed or properly closed; 5. Pellet quality is not good enough; 6. No sufficient pellets are being fed. <p>The stove temperature is too high, and stove stops delivering pellets to the burner due to safe temperature limit (85°C temperature control).</p>	<ol style="list-style-type: none"> 1. Refill the hopper; 2. Check the Error 3: no pellets is being delivered; 3. Wait for one hour until the stove has been cooled down completely; 4. See the maintenance requirements herein; 5. Only use approved pellets; 6. Ask for professional to adjust your stove and use local pellets. 7. Manually restart the stove after the stove has been totally cooled down. 	
3	No pellets is being delivered;	<ol style="list-style-type: none"> 1. The hopper is empty; 2. Faulty PC board or auger motor ; 3. Auger feeding mechanism is blocked by screws or other objects. 4. Due to over-temperature, the auger has reached STL (safe temperature limit) and stopped. 	<ol style="list-style-type: none"> 1. Check the hopper: refill it if necessary 2. Ask for professional to check the stove; if needed, please replace the faulty parts. 3. Clean the auger or hopper. 4. Manually restart the stove after the stove has been totally cooled down. 	

Item	Faults	Causes	Solutions	Remarks
4	The stove burns for a while, and then completely stops running.	<ol style="list-style-type: none"> 1. The stove temperature does not reach the minimum limit. 2. This may be caused by the temperature sensor. Replace it 3. Defective wire connection of temperature sensor. 4 Defective PC board. 	<ol style="list-style-type: none"> 1. Clean the tubes and vents, and then ignite again. 2. Ask for professional to replace the temperature sensor and check the PC board. 3. Check wires for the temperature sensor are properly connected. 	
5	The stove does not start	<ol style="list-style-type: none"> 1. No power supply. 	<ol style="list-style-type: none"> 1. Please check the power connection, if the grid provides sufficient voltage. 2. Check the safety fuse behind the hopper. 	
6	Ashes can be seen at outside of the stove.	<ol style="list-style-type: none"> 1. The front door is open; 2. The exhaust system is not sealed. 	<ol style="list-style-type: none"> 1. Only open front door when stove is not in use. During operation, always keeps door closed. 2. Seal any leakage of the exhaust device, with high temperature resistant AL strip, sealing rope, and heat resistant silicon materials. <p>Note: only check PC board and wire when stove is being unplugged. Repaired by professional only.</p>	
7	Abnormal noise	<ol style="list-style-type: none"> 1. Auger motor noise; 2. Blower noise; 3. Exhaust blower noise; 	<ol style="list-style-type: none"> 1. Check whether the auger motor runs properly. 2. Check the blower is working properly. If necessary, replace the high-temperature resistant damping cushion at the end of the blower; 3. Check the exhaust blower is working properly. 	The normal noise of the stove during running is about 52dB (A) because the motors keep on running.

9 Wiring Diagram

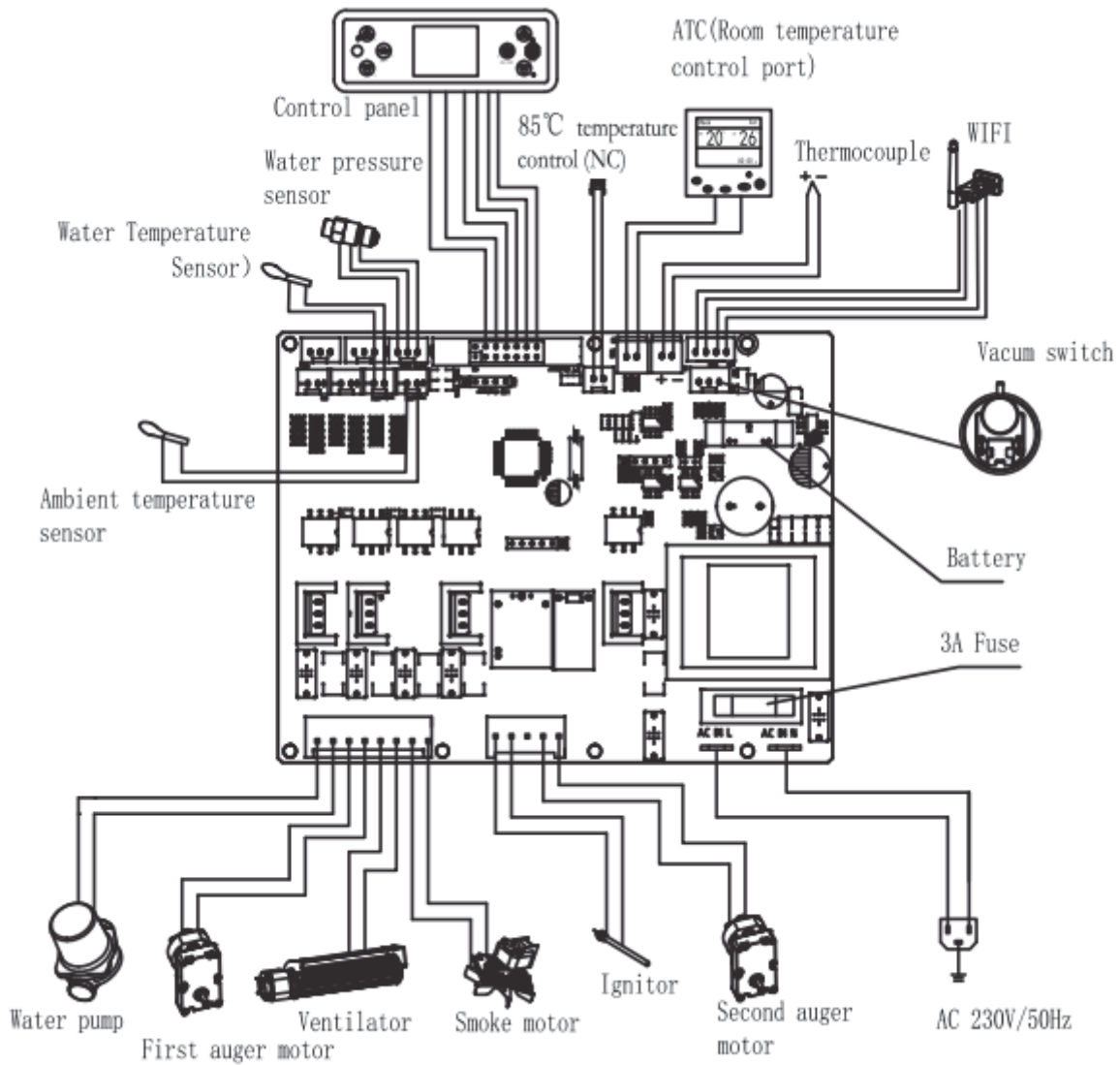

10 Warranty instructions

To apply for your warranty and see our list of Terms & Conditions please visit our website at :

<https://henleystoves.com/warranty/>

CE

ISO9001: 2008
