

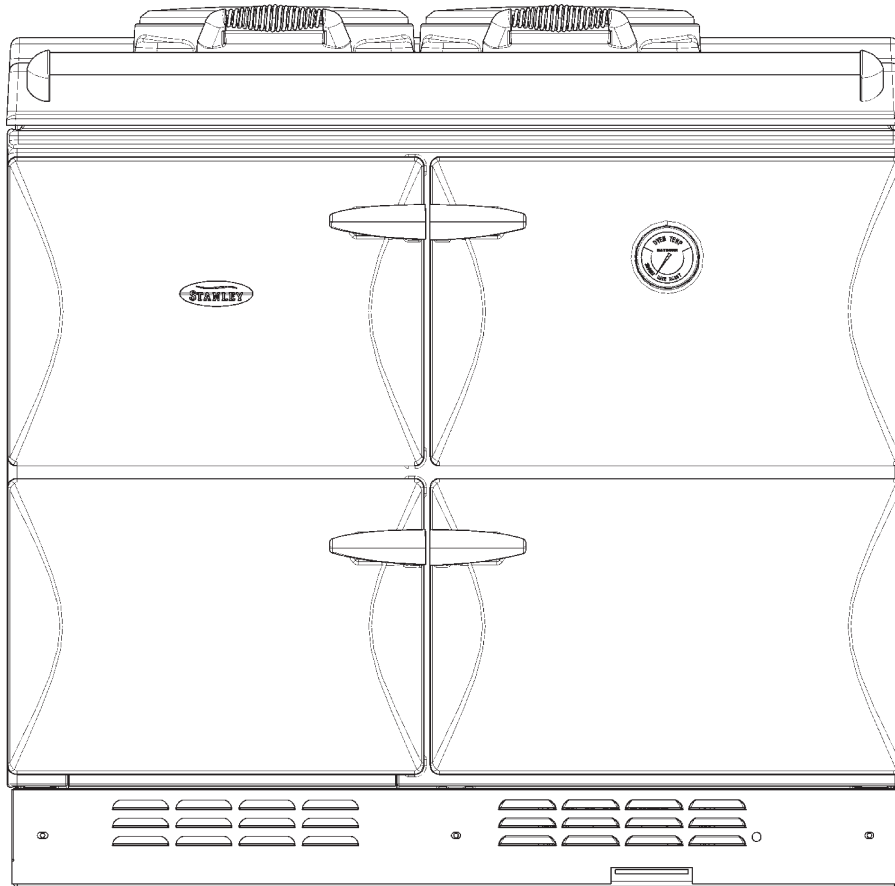

# Brandon OCD



DESN 515980

## *Users Instructions*

**PLEASE READ THESE INSTRUCTIONS BEFORE USING THIS APPLIANCE**

<b>SECTION</b>	<b>PAGE</b>
INTRODUCTION & USER INFORMATION	3
CONTROLS	4
THE COOKER	5
COOKING HINTS	6 - 7
THE BOILER	8
THE PROGRAMMER	8 - 10
CLEANING AND CARE FOR YOUR STANLEY APPLIANCE	11
BURNER RESET, OIL LEAK OR FAULT, POWER FAILURE, FUEL, AND SERVICING	12

# INTRODUCTION

Thank you for buying a Stanley Brandon. To get the best from it, please read and carefully follow the instructions before using it for the first time.

## Consumer Protection

As responsible manufacturers we take care to make sure that our products are designed and constructed to meet the required safety standards when properly installed and used.

## IMPORTANT NOTICE: PLEASE READ THE ACCOMPANYING WARRANTY

Any alteration that is not approved by Waterford Stanley could invalidate the approval of the appliance, operation of the warranty and could affect your statutory rights.

## Health and Safety

See Installation and Servicing Instructions for details.

## The Appliance

Your Stanley Brandon has been designed to provide cooking, central heating and domestic hot water when you require it. It can be run as an on/off cooker.

The boiler side of your Stanley Brandon should not be set to run below 60°C.

If the weather is very cold, or if you prefer, the appliance cooker burner can be run on a continuous low or high setting as required. **Do not use to warm a room with the appliance doors left open.**

This appliance is not intended for use by persons (including children) with reduced physical, sensory or mental capabilities, or lack of experience and knowledge, unless they have been given supervision or instruction concerning the use of the appliance by a person responsible for their safety.

Children should be supervised to ensure that they do not play with the appliance.

During use the appliance becomes hot.

**WARNING:** Accessible parts may become hot during use. Young children should be kept away.

This Stanley Brandon is for use with Kerosene C2 to BS 2869 only.

This appliance must be commissioned by an approved engineer.

A programmer is supplied and controls the cooking only on the appliance.

Two independently fired oil burners are fitted. These are:

1. The boiler burner which gives domestic hot water and central heating or domestic hot water only.
2. The cooker burner gives control of the hotplate and oven temperature.

Your Stanley comes complete with:

1 Meat Tin	1 Meat Tin Rack	1 Grill Tin	1 Installation Instruction
1 Solid Shelf	1 Grill Rack	1 Wire Brush	1 Servicing Instruction
1 Oven Retaining Grid Shelf	2 Lifting Eyes	1 Cook Book Questionnaire	1 Users Instruction
1 Standard Oven Grid Shelf	2 Lifting Hooks	1 Pre-paid Envelope	1 Appliance Warranty
1 Oil Filter			

# USER INFORMATION

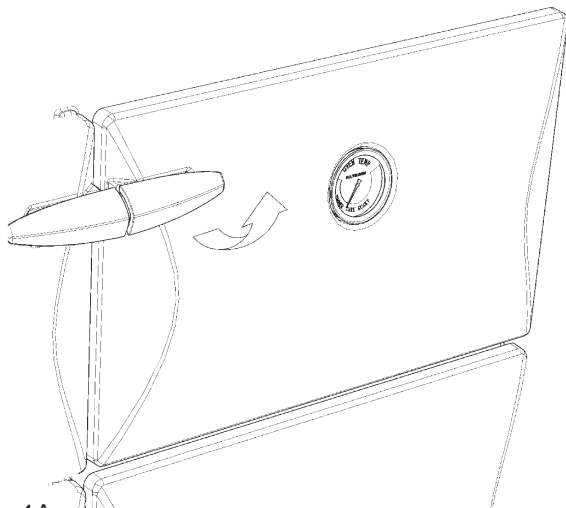
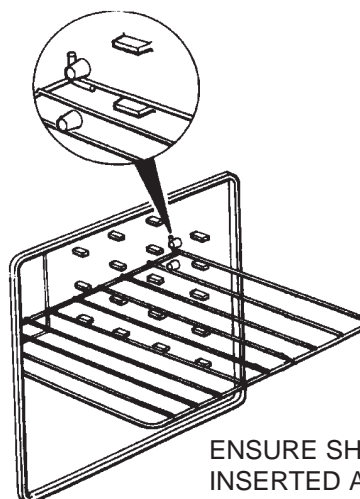

Fig. 1A



ENSURE SHELVES ARE INSERTED AS SHOWN.

Fig. 1B

# CONTROLS

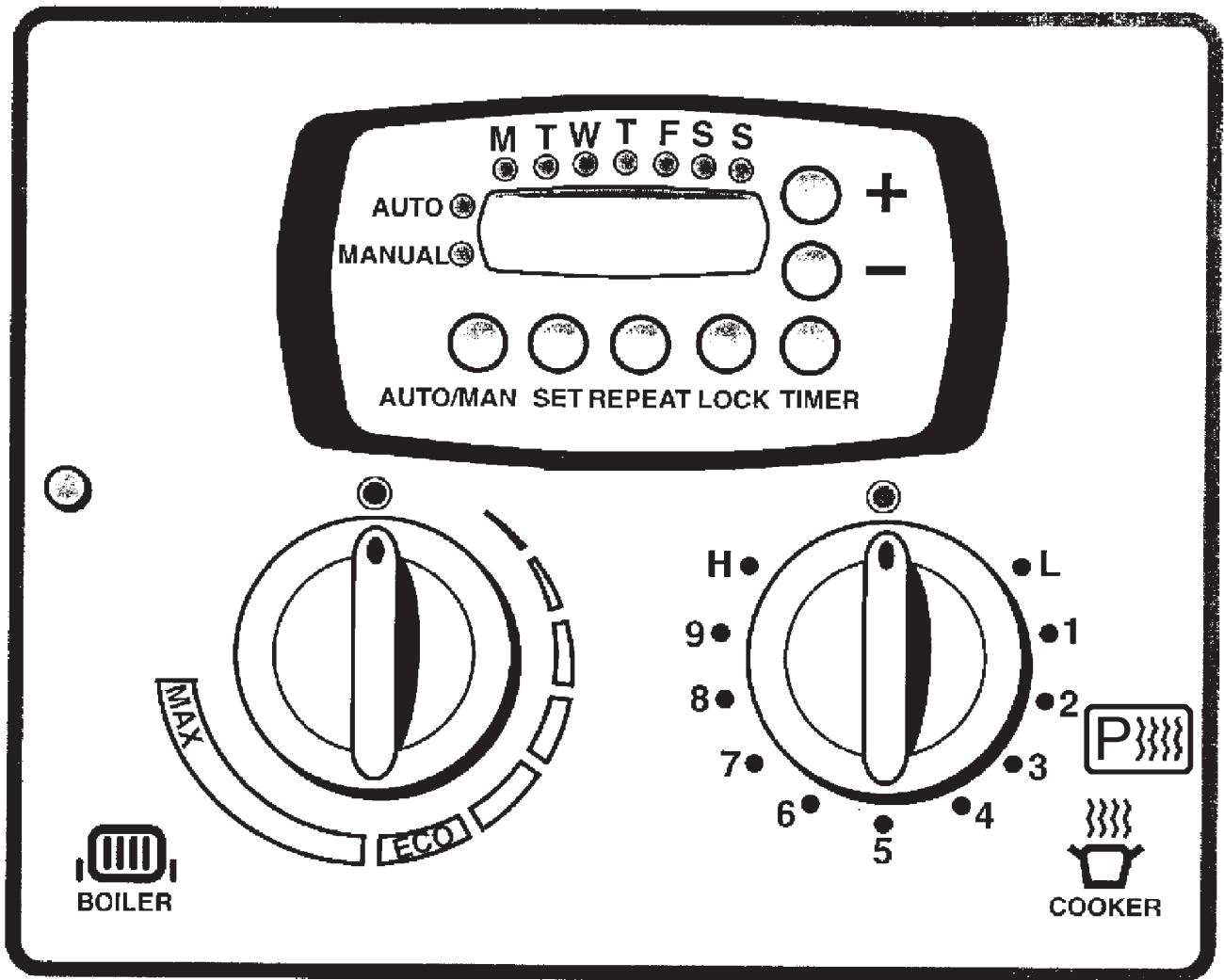

MARK	APPROX TEMP
LOW	120°C
1	140°C
2	150°C
3	160°C
4	180°C
5	190°C
6	200°C
7	220°C
8	230°C
9	240°C
HIGH	250°C



## THERMODIAL GUIDE

SIMMER	120°C - 150°C
BAKE	160°C - 200°C
ROAST	220°C - 250°C

## THERMODIAL

THE THERMODIAL ON THE MAIN OVEN DOOR IS A GUIDE TO THE CENTRE OVEN TEMPERATURE WHEN COOKING. SEE COOKING CHART ON PAGE 5 AND COOKING HINTS ON PAGE 6 FOR FURTHER INFORMATION

Fig. 2

## THE COOKER

### MAIN OVEN AND HOTPLATE CONTROL

The Main Oven and hotplate temperatures are controlled by the cooker thermostat control knob which is situated behind the controls door. See section 'CONTROLS' - Page 4.

Turning the control knob clockwise increases the temperature.

### THE HOTPLATE

The single hotplate of your Stanley Brandon is graduated in temperature. Just slide pans to a hotter or a cooler area depending on whether boiling or simmering is required.

The hottest area is in the middle left hand side.

The hotplate temperature is also variable, depending upon the setting used; the higher the setting then the higher the hotplate temperature.

Made of thick cast iron, the hotplate is machined flat. In order to ensure perfect contact and even heat distribution it is recommended that all pans and kettles have thick machined flat bases. Pans should also have tight fitting lids for greatest efficiency. Keep the insulated hotplate covers down when the hotplate is not in use to conserve heat.

Any spillage should be removed from the lids before opening.

### THE MAIN OVEN

The oven thermostat control knob is marked (OFF), then temperature graduated (See diagram, page 4).

### THE LOWER OVEN

The temperature of the cast iron Lower Oven is dependent on the temperature in the Main Oven. As a guide it is around half the temperature of the Main Oven for food such as meringues, casseroles, milk puddings etc. This means that it can be used as a cooking oven when the Main Oven is at a higher temperature ie. over 200°C (400°F).

If the appliance is left on a high setting for a lengthy time the Lower Oven may climb to a temperature higher than half that of the Main Oven temperature.

### THE COOKBOOK

When following the recipes, consult these Users Instructions to ascertain details relevant to this cooker.

### NOTE: SMOKE/SMELL EMITTED DURING INITIAL USAGE.

Some parts of the cooker have been coated with a light covering of protective oil. During initial operation of the cooker this may cause smoke/smell to be emitted and is normal and not a fault with the appliance, it is therefore advisable to open doors and or windows to allow for ventilation. Lift the lids to prevent staining the linings.

**NOTE:** Check that the plastic protection is removed from the oven doors before the Stanley Brandon is lit for the first time.

## COOKING CHART (MAIN OVEN)

	Temperature	Shelf	Approximate Time
Scones	220°C (425°F)	3	10 - 15 mins
Small Cakes	190°C (375°F)	3 or 4	15 - 20 mins (Turn the tray round halfway through cooking.)
Victoria Sandwich	180°C (350°F)	3 + 5	20 - 30 mins (Move the lower cake up when the top cake is cooked. For best results place the solid plain shelf on the top runner)
		OR	20 - 30 mins (Both cakes on one shelf)
Semi-rich fruit cake	150°C (300°F)	4	2 hours
Rich Fruit Cake	140°C (275°F)	4 or 5	Depending on size
Shortcrust - tartlets	200°C (400°F)	2 or 3	20 mins
Shortcrust Pie	200°C (400°F)	4 or 5	45 mins
Quiche	200°C (400°F) - 220°C (425°F)	Floor	45 mins (Turn round halfway through cooking)
Puff Pastry	210°C (410°F) - 220°C (425°F)	2 or 3	15 mins
Meringues	100°C (212°F) - 120°C (240°F)	5	1 1/2 - 2 hours
Casseroles	120°C (240°F)	4 or 5	3 hours or more
Bread - rolls	210°C (410°F) - 220°C (425°F)	2	15 - 20 mins
Bread - loaf	210°C (410°F) - 220°C (425°F)	4 or 5	35 mins
Soufflé	180°C (350°F)	4	30 mins

Shelf positions are counted downwards ie: top shelf position is number 1.

The positions are a guide only and can of course be altered to suit.

## COOKING HINTS

The ovens are indirectly heated from the outside by hot gases from the heat source so that no flame or elements are within the ovens. This means that full use can be made of the whole cooking space. Both ovens are vented so that cooking smells disappear to the outside.

### VENTING FAN

This is achieved with an automatic electric fan and this will run for 45 minutes after cooking has been completed.

### MAIN OVEN

This oven is hotter towards the top than the bottom.

For best results turn food during cooking.

On low settings the oven can be used for long slow cooking such as casseroles, stock soup, ratatouille, curries, meringues, rice pudding etc. Turn up to a higher setting for baking fruit cakes, victoria sandwiches, small cakes, souffles, scones, bread and roasting etc. (See temperature/setting chart on previous page for details).

One of the many benefits of the cast iron oven is that the floor of the oven is hot and can be used as a cooking area in its own right.

1. For Baking - no need to bake pastry cases or quiche "blind" just place the flan dish directly on the oven floor for the whole, or part of, the cooking time to achieve "soggy-free" pastry bases that are crisp and golden. In the same way an apple pie can be part cooked on the oven floor to ensure a well cooked base.
2. For frying - when the oven is hot the floor of the oven can be used for frying. Think of it as a hidden hot plate. A cast iron dish is recommended. Allow it to heat up first before adding the food. It's an excellent method for frying bacon and egg, fish such as trout/salmon or onions etc. Any fat splashes are carbonised on the inside of the oven so cleaning is minimal (carbonised crumbs can be brushed out using a stiff brush) and frying smells are taken away through the flue.

The top of the oven is where the grilling takes place. Do this when the oven is turned up to a high setting. The heat radiating from the roof of the oven seals and cooks the food efficiently. Arrange the food on the grill rack in the meat tin set on the highest usable shelf position.

Cast iron retains the heat so you can peep at a cake or soufflé to see how it is cooking without it sinking. For safety reasons the oven grid shelves are non-tilt, use as directed on the opposite page and USER INFORMATION, Page 3.

### THERMODIAL

The thermodial on the Main Oven door is a guide to the condition of the internal oven. On opening, the pointer will appear to drop as it registers air away from the oven, do not worry, close the door and after a few minutes it will regain its original position.

### LOWER OVEN

A valuable oven for slower more gentle cooking when the Main Oven is turned up high, as it is roughly half the temperature of the Main Oven. Ideal for meringues, casseroles, milk puddings, egg custards etc. When cooking a casserole in this oven allow it to heat through and simmer for 5-10 minutes on the hotplate or main oven floor before transferring to the Lower Oven. Although there are runners on the sides of the oven for the grid shelf/meat tin, dishes may also be cooked on the floor of the oven.

### SOLID SHELF

The solid shelf can be used as a baking sheet or as a heat deflector to protect food from over browning/cooking. It is ideal as a solid baking sheet as it maximises the whole oven area. When in position the solid shelf and the space above can still be used for cooking, while it is protecting the food below. As a heat deflector slide it in two runners above the food. To be effective it must be used from cold and therefore it should be stored outside the oven.

### HOTPLATE

Apart from its use for boiling and simmering, the hotplate can be used directly, for making toast, toasted sandwiches, drop scones, see the cook book for details. After cooking directly on the hotplate make sure you brush off any crumbs or this could impair the boiling performance of the kettle or saucepans.

### ACCESSORIES

Further accessories, tins, shelves, solid shelves, saucepans, aprons and gauntlets, etc are available from your local Stockist.

### LOCATION OF OVEN GRID SHELVES

To ensure the correct operation of the oven grid shelves ensure that they are inserted as shown. (See section 'USER INFORMATION') - page 3.

The oven shelf with the front stop, is to be used with the grill tin supplied.

Locate the oven shelf on the runners as shown in Fig. 1B.

Locate grill tin on the oven shelf with the holes facing the left hand side of the oven.

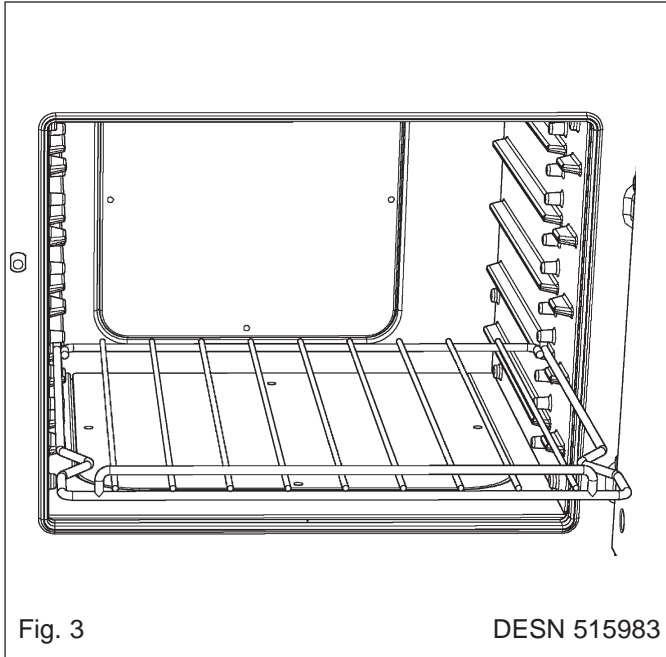

### DOORS

To open the doors. Twist the handle slightly to disengage the door catch from the locking spindle and pull door open (See section 'USER INFORMATION') - page 4.

To close the doors. Gently push the door shut until the door catch engages with the locking spindle.

**IT IS NOT ADVISABLE TO PUT VERY WET CLOTHES OR TOWELS ONTO THE HANDRAIL, AS THIS MAY CRAZE THE ENAMEL.**

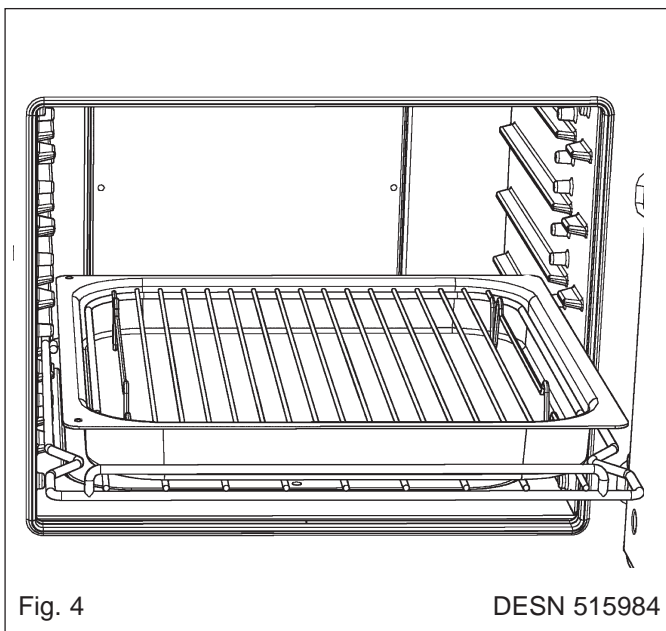

## THE BOILER

The temperature of the hot water supplied can be adjusted by means of the boiler thermostat knob. This knob can also be used to turn the boiler off.

To inhibit internal corrosion of the boiler heat exchanger it is important not to operate the boiler below 60°C.

An ideal setting for summer hot water, and to keep the temperature above 60°C, can be achieved using the 'ECO' setting.

### 'ECO' SETTING

The 'ECO' setting on the boiler is a range at which the boiler operates at maximum efficiency.

The boiler thermostat knob is situated behind the control door (See Fig. 2). Turn the knob clockwise to increase the temperature of the water.

Should your heating water system be of an unvented design i.e. Pressurised System. It is important not to keep resetting the boiler safety cut-out as this may indicate a loss of secondary water.

Check also your system pressure gauge.

### FROST PRECAUTIONS

In the event of the boiler being OFF for long periods during very cold weather, the advice of your installer should be obtained.

## BURNER

The burner can be re-set after 1 minute by pressing the REPEAT button.

In the event of repeated failure switch off the oil and electrical supply to the appliance and contact your local Technical centre or authorised service engineer.

## THE PROGRAMMER

### WHAT IT DOES

The programmer is a 7-day 2 event programmer which allows the user to set 2 periods of the day in which the cooker will turn on and then off. A typical example of how this may be used is 'on' for use in the morning and then 'off' when going out, and then 'on' if needed for cooking later in the day and then 'off' when cooking is finished.

The programmer can be set for different time each day (e.g. morning and evening). However, as many people have a similar routine through the working week, there is a repeat function which allows the setting from the previous day to be copied.

However, it may still be set each day differently.

### FUNCTIONS

The **AUTO/MAN** functions allow the user to turn the cooker on, by simply turning the knob to the required cooking mark temperature, or by having it turn on at 2 set periods within the day.

The minute minder function works as a countdown timer to ease with cooking. When the timer has counted down the display will flash 00:00 and a buzzer will sound.

### SETTING INDIVIDUAL DAYS

To allow the user to change an individual day without having to run throughout the entire week, there is the ability to change just one day (e.g. days holiday) without altering the previous settings.

### SETTING THE TIME OF DAY

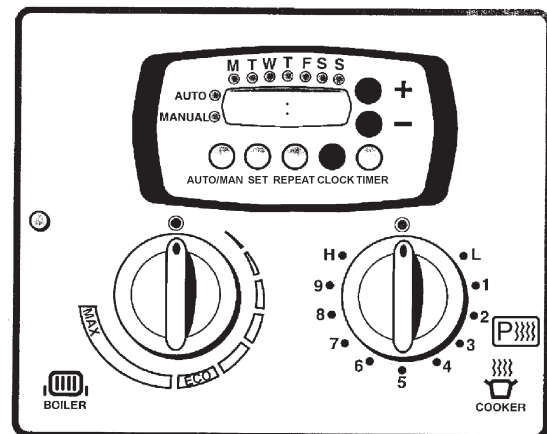

: flashes when time is set

Fig. 5

DESN 515996

1. Press the **CLOCK** button once. Adjust the day using + and -. Press the **CLOCK** again.
2. Adjust the hour using + and -. Press **CLOCK** again.
3. Adjust the minutes using + and -. Press **CLOCK** to confirm.

The day light will go out.

**PLEASE NOTE:** Hold + and - down to increase or decrease.



## AUTO/MANUAL CONTROL

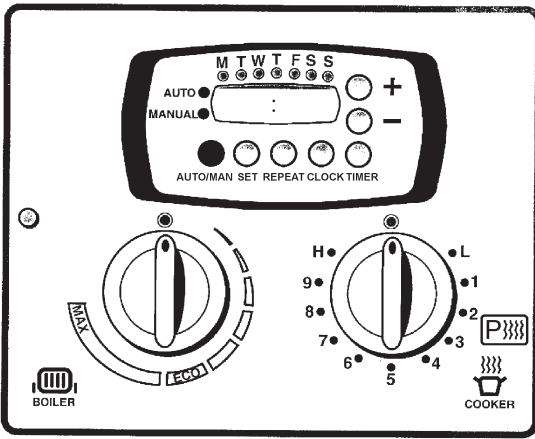

Fig. 6

DESN 515997

1. By pressing the **AUTO/MAN** button, this allows the oven to be used with the programmer or used manually.
2. An LED will display what is currently set.

## SETTING THE PROGRAMMER - WEEKLY (1)

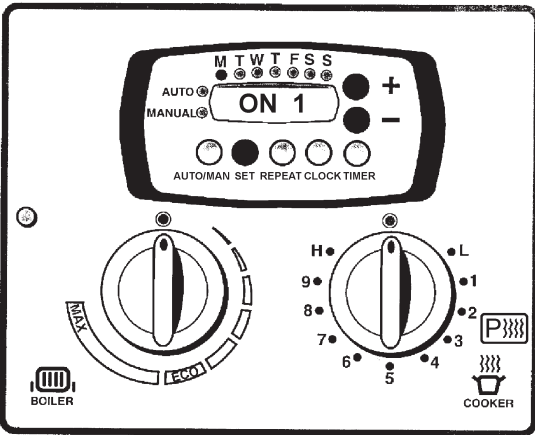

Fig. 7

DESN 515998

1. Ensure that the **AUTO** mode is being used when setting the programmer.
2. Press the **SET** button twice.
3. The display should alternate between **ON1** and the time of day currently set.
4. Adjust to the time required by using **+** or **-** buttons to set time you wish cooker to turn on (e.g. morning).
5. Press **SET** once to confirm time.

## SETTING THE PROGRAMMER - WEEKLY (2)

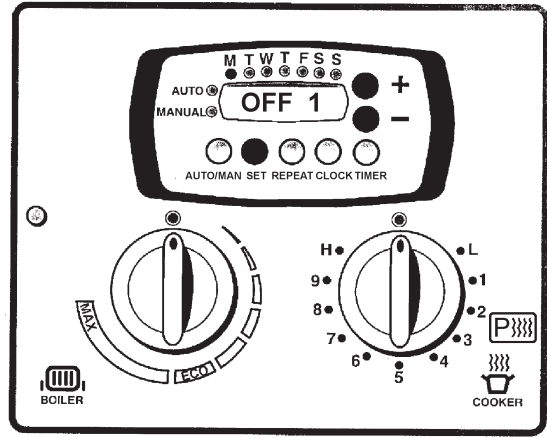

Fig. 8

DESN 515999

1. The display should alternate between **OFF 1** and the time of day currently set.
2. Adjust using **+** or **-** to set the time the cooker is to turn off.
3. Press **SET** once to confirm.

## SECOND EVENT

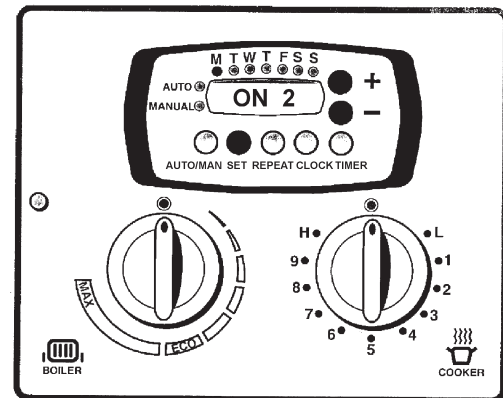

Fig. 9

DESN 516000

1. The display should alternate between **ON2** and time of day currently set.
2. Adjust using **+** or **-** to set the time the second event is to begin (evening).
3. Press **SET** once to confirm.
4. If the second event is not required, set the time to 00:00 and then press **SET**.

## SECOND EVENT

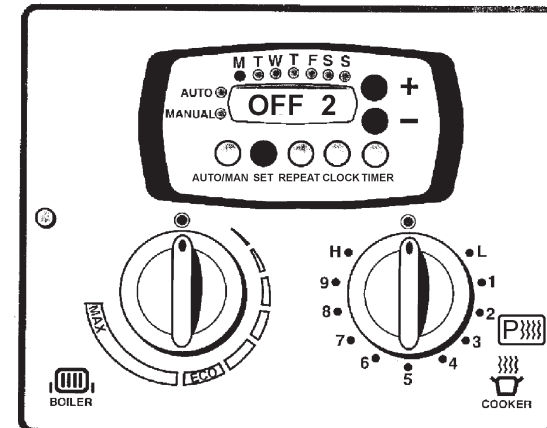

Fig. 10

DESN 516001

1. The display should alternate between **OFF2** and the time of day currently set.
2. Adjust using **+** or **-** to set the time the second event is to end,
3. Press **SET** once to confirm.
4. Again, if this is not required set the time to 00:00 and then press **SET**.

### REPEATING DAYS

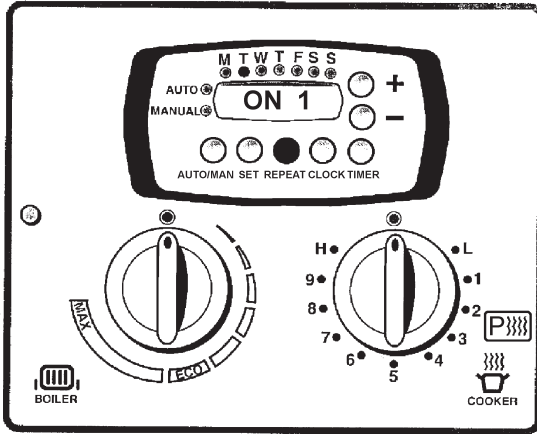

Fig. 11

DESN 516002

1. To repeat the event of the previous day, press the **REPEAT** button once.
2. To repeat the second event of the previous day, press the **REPEAT** button once.
3. Alternatively, to set different times from the previous day, alter the required time.

### SETTING THE PROGRAMMER - DAILY

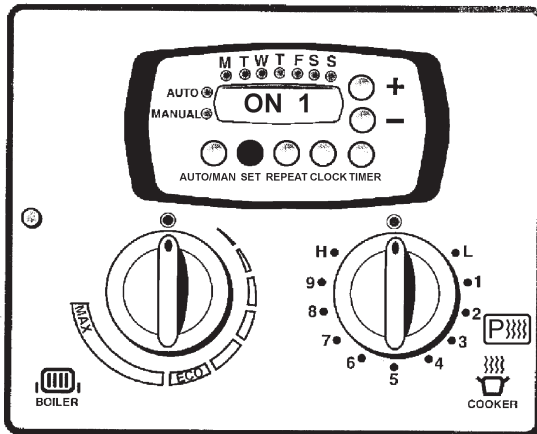

Fig. 12

DESN 516003

1. To set individual days, press **SET** once.
2. Adjust to the day required using **+** or **-** buttons.
3. Press **SET** to confirm the day chosen.
4. Adjust to the new times required as before.
5. Again, if an event is not needed set to 00:00.
6. Once day is set (both events), display should fault to time of day.

### SETTING THE MINUTE MINDER

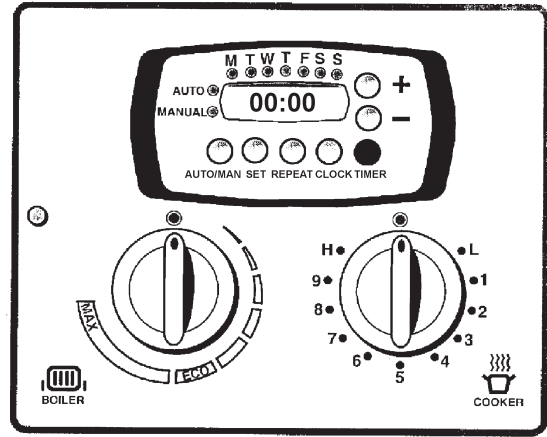

Fig. 13

DESN 516004

1. Press the **TIMER** button once.
2. 00:00 should be displayed.
3. Adjust to the time required using **+** or **-** buttons.
4. Press **TIMER** to confirm.
5. Press **TIMER** to show the time of day. To check the remaining time on the minute minder, press **TIMER** once then press **TIMER** again to show the time of day. Once the timer has finished, it will flash 00:00 and a buzzer will sound. To stop press **TIMER**.

To return to **MANUAL** mode at any time whilst programming press the **AUTO/MAN** button and time of day will be displayed.

## Cleaning and Caring for your Stanley Appliance

**REMEMBER: BE CAREFUL OF THE HOT APPLIANCE.**

**DO NOT USE A STEAM CLEANER TO CLEAN THIS COOKER.**

### Enamelled Top Plate and Front Plate

- It is not advisable to put very wet clothes onto the handrail, as this may craze the enamel.
- To keep the vitreous enamelled surface bright and clean, wipe over daily with a soapy damp cloth, followed by a clean dry cloth.
- Wipe off any condensation on the front plate as they occur or the vitreous enamel may be permanently discoloured.
- If milk or fruit juice or anything containing acid is spilt on the top plate or down the cooker, be sure to wipe it immediately or the vitreous enamel may be permanently discoloured.
- Keep a damp cloth handy while cooking, to wipe up spills as they occur, so they do not harden and become more difficult to remove later. Look for cleaners carrying the VEA (Vitreous Enamel Association) approval logo as this indicates they can be used on your Stanley Appliance.
- For stubborn deposits, gentle localised soaking, not flooding is easier than rubbing and hot water and detergent will soften most burnt on stains in 10 minutes.
- A soap impregnated pad can be carefully used on the vitreous enamel (look for VEA mark on suitable cleaners).

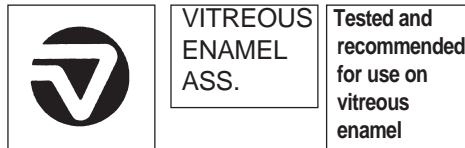

**Important:** Waterford Stanley recommend Vitreous Enamel Association approved cleaners for cleaning the vitreous enamelled surfaces of this product.

But they are unsuitable for use on chrome and stainless steel components, including the hand rails and their brackets.

The insulating covers should be cleaned regularly with a NON-ABRASIVE mild detergent, applied with a soft (coarse free) cloth and lightly polished up afterwards with a soft (coarse free) duster or tissue, to bring it back to its original lustre.

**DO NOT USE ABRASIVE PADS, THAT ARE NOT VEA APPROVED, OVEN CLEANER, OR CLEANERS CONTAINING CITRIC ACID ON ENAMELLED SURFACES.**

### Oven Door Linings

- Using oven gloves carefully lift off the oven doors, lay them on a tea towel to protect the enamel. They can then be cleaned with a cream cleanser or soap impregnated pad. Do not however, immerse the doors in water as they are packed with insulating material which will be damaged by excessive moisture.

### Insulating Lids

- **Stainless Steel** Wipe over with a soapy damp cloth followed by a polish with a clean dry cloth.
- **Linings** The linings of the insulating lids may be cleaned with a cream cleanser or soap impregnated pad.

### Ovens and Hotplate

- Use a wire brush for cleaning the hotplate to remove burnt on spills.
- In the main oven spills and fat splashes are carbonised at high temperatures, occasionally brush out with a wire brush. Do not use oven cleaners.
- The lower ovens should also be brushed or wiped out occasionally.

**DO NOT USE ANY OVEN CLEANERS**

### Accessories

- Oven furniture such as meat tins, solid plain shelves, oven grid shelves and grill racks should be cleaned in hot soapy water, soak if necessary, a nylon scouring pad can be used.

**DO NOT PLACE IN A DISHWASHER OR USE CAUSTIC CLEANERS.**

## BURNER RESET

Reset buttons are located behind burner door. The cooker burner, under normal conditions will flash every 15 seconds. This is part of the system monitoring. The boiler burner does not flash.

If a fault occurs on either burner then it automatically shuts down and the red button on the burner control box will be illuminated.

### OPERATE BY PRESSING WITH FINGER ONLY

Please wait at least 60 seconds between resetting the lockout button.

If for example the storage tank has been replenished after the oil supply tank ran out, and resetting the lockout button does not light the burner immediately, it will be necessary to repeat the sequence.

Continued lockouts indicate a burner or oil supply malfunction. The fault should be diagnosed and rectified.

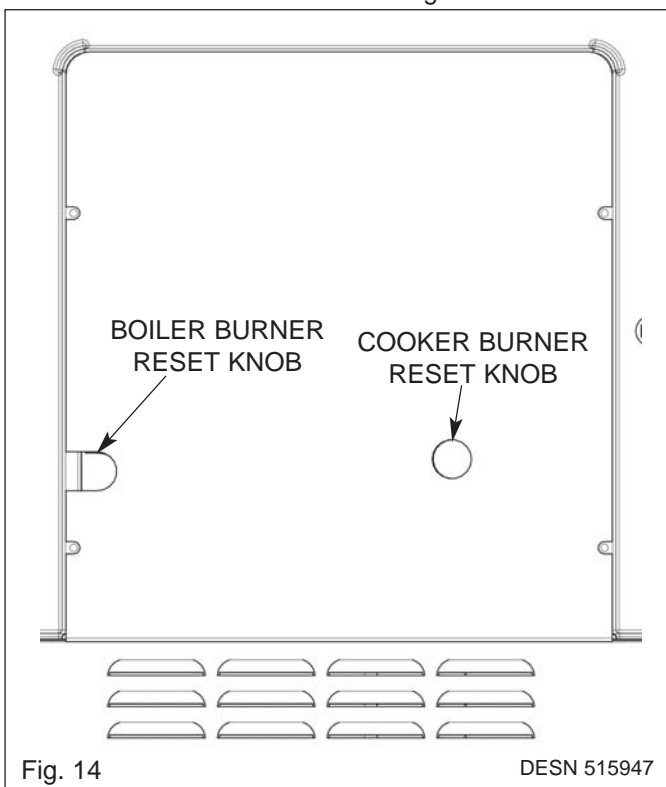

## OIL LEAK OR FAULT

In the event of repeated failure switch off the oil and electrical supply to the appliance and contact your installer/service engineer.

If an oil leak or fault exists or is suspected the unit must be isolated from the oil and electrical supply. The appliance must not be used until the fault has been rectified.

## POWER FAILURE

In the event of power failure your appliance will become inoperative. When the power is restored it will automatically restart, if programmed or manually set to do so.

## FUEL

Please endeavour to see that when your fuel is being delivered to your storage tank, that the appliance is left off during delivery, and preferably for a period of 1 hour afterwards to allow sediment within the tank to settle.

This is particularly important for oil systems using two pipe flow and return.

Also endeavour to avoid running out of fuel, by seeing that the storage tank is replenished in good time. This will help avoid nuisance breakdowns which can result through fuel starvation.

## SERVICING

With normal use a boiler/cooker annual flueway clean and burner maintenance should be carried out immediately before the end of the heating season.

An additional flueway clean halfway through the heating season may be necessary in some cases - see servicing instructions.

A HOT APPLIANCE CANNOT BE SERVICED.

Both cooker and boiler thermostat knobs should be turned OFF, the night preceding the day of the servicing so that the appliance will have cooled down by the following morning.

This product **MUST** be serviced at regular 12 monthly intervals to optimise its safety, efficiency and performance.

## FAULT INDICATOR

Should a problem arise with the cooker or boiler, an alarm or a error code fault will be displayed on the RH side for the cooker and the LH side for the boiler.







For further advice or information contact your  
local distributor/stockist

With Waterford Stanley's policy of continuous  
product improvement, the Company reserves the  
right to change specifications and make  
modifications to the appliance described at any  
time.



Supplied by

Waterford Stanley Ltd  
Units 210  
IDA Industrial Estate  
Cork Road  
Waterford  
Ireland

Tel: (051) 302300 Fax: (051) 30-2315

[www.waterfordstanley.com](http://www.waterfordstanley.com)